



MORO USA, INC.

ST. LOUIS, MO OFFICE
 Po Box 632
 Union, MO 63084
 (866) 383-6304
 Fax: (636) 583-2044

PITTSBURGH, PA OFFICE
 SALES OFFICE
 (800) 383-6304
 (412) 415-0421
 Fax: (412) 415-3154

Email: sales@morousa.com
www.morousa.com

PM70T Spare Parts

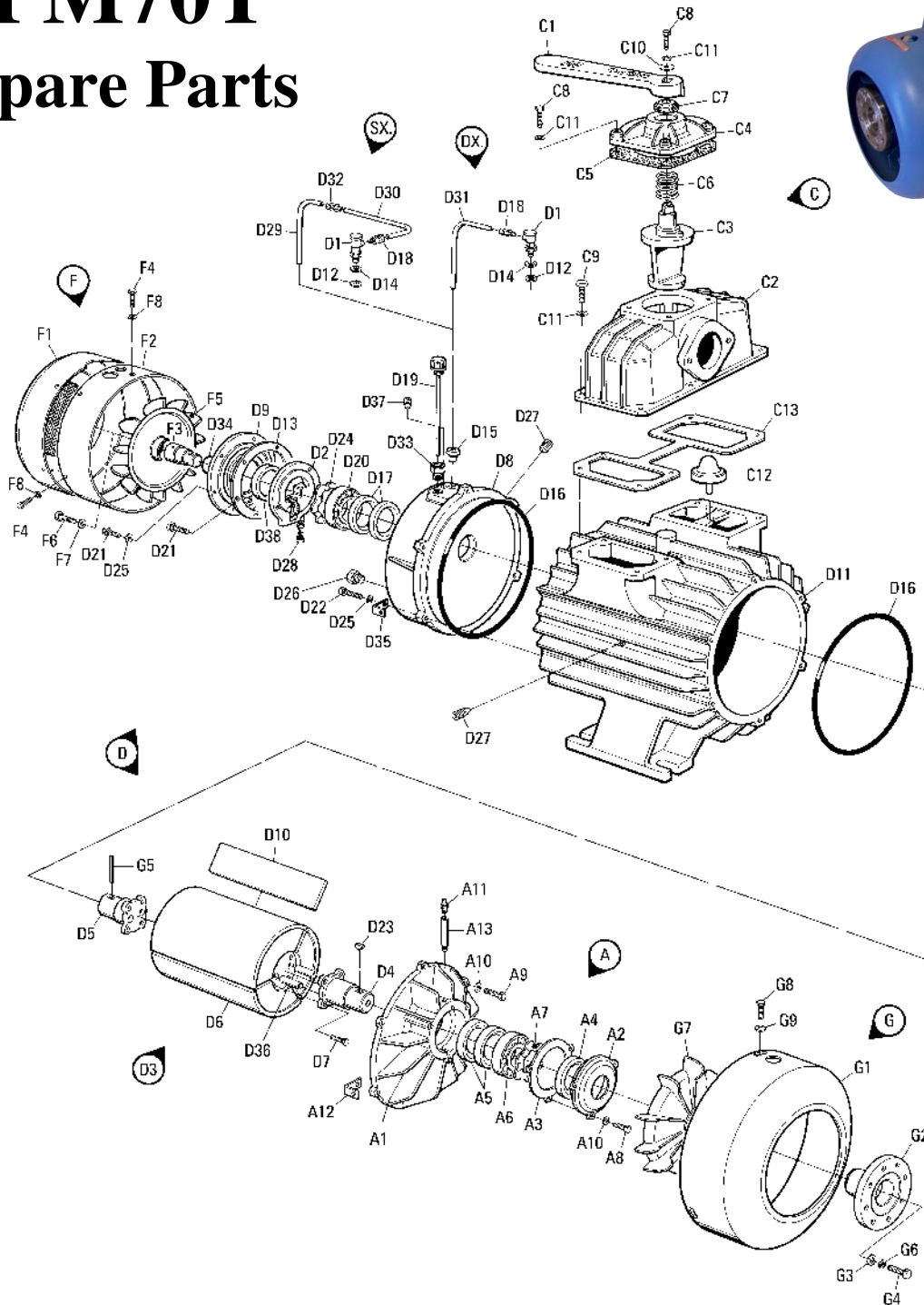

PM70T

Pos.	Quantity	Part No.	Description
Front group direct jack			
A1	1	6.610400620-2	Flange
A2	1	6.663400310-2	Cover
A3	1	6.680600131-2	Gasket
A4	1	6.921002004-2	Ring seal
A5	2	6.921002000-2	Ring seal
A6	1	6.931004004-2	Ball bearing
A7	1	6.963005004-2	Ring
A8	3	6.961013002-2	Screw
A9	6	6.961013003-2	Screw
A10	9	6.964001002-2	Washer
A11	1	6.965001001-2	Grease nipple
A12	3	6.612004470-2	Support
A13	1	6.673002000-2	Lubrication pipe
Collector set			
C1	1	6.602400040-2	Handle
C2	1	6.626400630-2	Manifold
C3	1	6.626400280-2	Change-over Device
C4	1	6.663300330-2	Cover
C5	1	6.680600160-2	Gasket
C6	1	6.690000342-2	Spring
C7	1	6.921000074-2	Ring seal
C8	5	6.961013002-2	Screw
C9	6	964007001	Screw
C10	1	6.964005005-2	Washer
C11	11	6.964001002-2	Washer
C12	1	6.692500020-2	Valve
C13	1	6.680502610-2	Gasket
Casing set			
D1	1	6.453300090-2	Oil valve
D2	1	6.481201101-2	Oil Pump
D3	1	4753-0022-1	Rotor
D4	1	6110-0098-2	Hub
D5	1	6110-0099-1	Hub
D6	1	6534-0083-1	Rotor
D7	8	6.961075103-2	Screw
D8	1	6.610400850-2	Flange
D9	1	6103-0012-0	Cover
D10	3	6575-0053-2	Vane
D11	1	6624-0052-0	Housing
D12	1	6.683300030-2	Washer
D13	1	6.680600350-2	Gasket
D14	1	6.683300070-2	Washer
D15	1	6.684500030-2	Plug

Pos.	Quantity	Part No.	Description
D16	2	6.921003146-2	O-Ring
D17	2	6.921002000-2	Ring seal
D18	1	92-4017-007	Fitting
D19	1	6.601500030-2	Rod
D20	1	6.931004004-2	Ball bearing
D21	7	6.961013002-2	Screw
D22	6	6.961013003-2	Screw
D23	1	96-3000-018	Key
D24	1	6.963005004-2	Ring
D25	13	6.964001002-2	Elastic washer
D26	1	6.965023000-2	Drain plug
D27	3	6.925070000-2	Conical plug
D28	1	6.644500000-1	Oil filter
D29	1	6760-0450-0	Tube sx
D30	1	6760-0451-0	Tube sx
D31	1	6760-0453-0	Tube dx
D32	1	924023100	Pipe fitting
D33	1	6.673002010-2	Pipe fitting
D34	1	6.921003103-2	O-Ring
D35	3	6.612004470-2	Support
D36	2	96-4027-002	Elastic pin
D37	1	96-1090-000	Dowel
D38	1	6.921002004-2	Ring seal
Fire-fans rear set			
F1	1	6.540000240-2	Convejour
F2	1	6.645000110-2	Sheathing
F3	1	6.655000100-2	Hub
F4	7	96-1075-001	Screw
F5	1	6.929080000-2	Fan
F6	1	6.961020003-2	Screw
F7	1	6.964001003-2	Elastic washer
F8	7	964007001	Flat washer
Fire-fans front set			
G1	1	6.640000210-2	Convejour
G2	1	6.656000200-2	Hub
G3	1	6.683000101-2	Washer
G4	1	6.961021001-2	Screw
G5	1	964018019	Plug
G6	1	6.964001003-2	Elastic washer
G7	1	6.929080000-2	Fan
G8	3	96-1075-001	Screw
G9	3	964007001	Washer
		6.889900850-2	Kit of gaskets AC w/fans