



**MORO KAISER
COMPONENTS**

EN

OPERATOR'S MANUAL
Original Instructions



VACUUM PUMP

MODEL: PM90T TURBO

This page is intentionally blank.



-- Good choice!

Thank you for choosing MORO KAISER S.R.L..

Our pumps are designed and manufactured so to provide the best performances, maximum operating economy and safe and easy use. They are carefully tested and checked in order to ensure the customer a reliable and safe product.

-- Index

A.	Manuals and technical guidebooks, basic documentation	pag.	1
A.1	Who should read this document?	pag.	1
A.2	The manual	pag.	1
A.2.1	Safety above all	pag.	1
A.2.2	Care of the manual	pag.	2
A.2.3	Revisions of the release	pag.	2
A.2.4	Additional documentation	pag.	2
A.3	How to read the manual	pag.	3
B.	Warnings, signs and symbols	pag.	4
B.1	The “WARNING” symbol.	pag.	4
B.1.1	The most important symbol for your safety.	pag.	4
B.1.2	Colours and forms of the symbology.	pag.	5
B.1.3	Description of the symbols	pag.	6
C.	General description.	pag.	10
C.1	Description	pag.	10
D.	Warnings	pag.	11
D.1	Responsibilities.	pag.	11
D.2	Designated use.	pag.	11
D.3	Staff training	pag.	12
D.4	General warnings about safety.	pag.	12
D.4.1	Norms and laws	pag.	12
D.4.2	Safety devices, protection and signaling.	pag.	12
D.4.3	P.P.E. Personal Protective Equipment	pag.	13
D.4.4	General rules of behaviour	pag.	13
D.4.5	Work environment, general indications.	pag.	13
D.5	Dangers	pag.	15
D.5.6	Dangers due to operating procedures:	pag.	15
D.5.7	Residual hazards and unsafe conditions for the pump.	pag.	17
D.5.8	Dangers coming from general maintenance:	pag.	19
D.6	Precautions.	pag.	20
D.6.9	When using and maintaining:	pag.	20
E.	Dimensions and technical characteristics	pag.	21
E.1	Performance table.	pag.	21
E.2	Characteristics and dimensions	pag.	22
E.3	Identification	pag.	22
G.	Installation of the pump	pag.	23

G.1	Packing and lifting	pag.	23
G.2	Setup.	pag.	24
G.3	Plant diagrams	pag.	28
G.3.1	Vacuum system diagram.	pag.	28
G.3.2	Hydraulic motor system diagram	pag.	29
H.	Start-up, put into operation	pag.	30
H.1	Lubrication	pag.	30
H.1.1	Oil table.	pag.	32
H.2	System put into operation	pag.	33
H.3	Change of pump setup for user requirements - Procedures.	pag.	34
H.3.2	Procedure for changing the oil tank side.	pag.	34
H.3.3	Procedure for changing vacuum pump rotation	pag.	37
J.	Maintenance of the pump	pag.	41
J.1	Running in.	pag.	41
J.2	Periodic checks.	pag.	42
J.3	Internal pump body flushing procedure.	pag.	43
J.4	Vane wear control procedure	pag.	44
J.5	Troubleshooting	pag.	45
K.	Technical drawings and exploded views	pag.	46
K.1	References	pag.	46
	Spare parts PM90T Vacuum pump - left version	pag.	47
	Spare parts PM90T Vacuum pump - right version	pag.	51
	Spare parts PM90T Hydraulic motor kit	pag.	55
	Spare parts PM90T-PM150T Pneumatic control kit	pag.	56
N.	Directives, Norms and evaluations	pag.	57
N.1	Directives and Norms	pag.	57
N.1.1	Directives	pag.	57
N.1.2	Safety regulations.	pag.	57
N.2	CE Certificate of conformity	pag.	58
P.	Disassembly, scrapping and disposal of the equipment.	pag.	59
P.1	Separate and dispose the different types of material	pag.	59
Q.	Ecology and the environment	pag.	60
Q.1	Storage and disposal	pag.	60
Q.1.1	Specific symbols	pag.	60
Q.2	Warnings.	pag.	61
R.	Assistance	pag.	62
R.1	Assistance, maintenance and services.	pag.	62
R.2	Warranty regulations.	pag.	62
R.2.1	Duration	pag.	62
R.2.2	Validity.	pag.	63
R.2.3	Limitations and Liability.	pag.	63
R.2.4	Settlement of Disputes	pag.	63
S.	Contacts	pag.	64
S.1	Information to get in contact with us	pag.	64

Manuals and technical guidebooks, basic documentation.



A. Manuals and technical guidebooks, basic documentation

The manuals and the technical guidebooks, as this document, are essential for your work. Make sure you have the most complete and updated documentation possible. Take all your time to read carefully the contents of these documents in order to learn everything about the functioning and the use of your pump.

A.1 Who should read this document?

This document is intended for the operators that work with the pump or that are in some way responsible for it. The main figures intended are the pump responsible, the qualified technician, the operator, the maintenance technician and the installer.

A.2 The manual

This guidebook will help you working with our products with particular attention for all that concerns safety.

Read the manual BEFORE using the pump

A.2.1 Safety above all

- The manual is an integral part of the pump and it's the guide for a correct and safe use of the pump. Read it carefully.
- Reading the manual means “work safely”.
- It is essential to know the limits within which the pump can work safely in order to protect both the operators and the environment from any risk. This manual will help you getting all the important information to work safely with our pumps.

- The pump is ensured in accordance with the contractual agreements. The warranty, however, is void if all the rules and instructions included in this manual have not been complied.
- The “non original” spare parts are not authorized by the Manufacturer who’s not held responsible for any damage caused due to their use.
- For any doubt or question regarding safety, please do not hesitate to contact your Dealer or the Manufacturer.

A.2.2 Care of the manual

- Take care of the manual and keep it in a handy place so it can be promptly consulted.
- This manual must always be kept together with the pump so it’s mandatory to pass it to any other new owner.
- Should this manual get lost, destroyed or be in poor conditions, ask your Dealer or the Manufacturer directly for a new copy, providing the identification data of the pump.

A.2.3 Revisions of the release

- In order to improve the product, the Manufacturer reserves the right to update this release by making changes without notice.
- Any unauthorised copying, disclosure or distribution of this manual, even in part, is expressly forbidden.

A.2.4 Additional documentation

When available, the additional documentation of groups and devices that are manufactured by third parties is enclosed to this manual in order to give the operators and the manufacturer technicians all the information possible about the functioning, the use and the maintenance of the pump.

A.3 How to read the manual

- A fundamental indication or information that requires special attention is printed in “bold text”.
- The “italic text” is used when referring to norms or rules taken from other documents and for images legends.
- **NOTE:** the “NOTE” gives the reader additional information about the topic.
- Typical scheme of a general ATTENTION message.

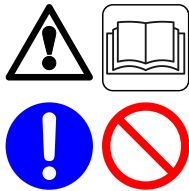

- **WARNING:** the triangle with the exclamation mark is a clear signal of ATTENTION and usually is followed by a symbol that explains the source of danger and by other circular symbols that specify obligations and prohibitions.

B

Warnings, signs and symbols.

B. Warnings, signs and symbols

B.1 The “WARNING” symbol

B.1.1 The most important symbol for your safety



this symbol means:

WARNING!

it's for your own safety!

- This symbol alerts the operator about potential dangers for persons, animals or things with real chance of serious injuries or damages.
- It refers to regulations and norms of use and maintenance.
- It highlights dangerous or prohibited working activities and procedures.
- It indicates the operators the risk of damaging the pump.
- Failure in observing the instructions preceded by this symbol can result in accidental serious injuries, pump damages or death.
- Description of symbols and signs.

B.1.2 Colours and forms of the symbology.

Forms and colours of signs and labels follow the indications of the national and international regulations D.L. n.81 of April 9th 2009, ANSI Z535, ISO 3864-1,2.

It is important for your own safety to understand quickly and easily the message communicated by symbols and colours.



- The signs of **WARNING**, **DANGER** or **CAUTION** are traced in black colour on yellow or red background.
- Usually the warning or caution signs have triangular shape.











- The signs of **DISPOSITION** or of **OBLIGATION** are traced in white colour on blue background.
- Usually the disposition or obligation signs have circular shape.







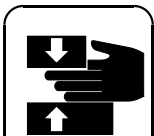



- The **PROHIBITION** signs are traced in black colour on white background behind a crossed red circle.
- Usually the prohibition signs have circular shape.



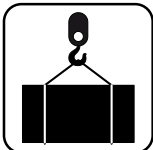
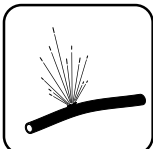

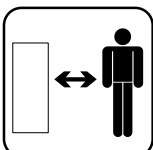





B.1.3 Description of the symbols

Through all its manuals and documentations, you will find several symbols and signs that indicate the possible risks and dangers

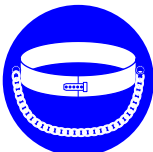
SYMBOL	DESCRIPTION
	<ul style="list-style-type: none"> • DANGER, ALARM. • This general symbol is often paired with one of the symbols listed below.
	<ul style="list-style-type: none"> • WARNING, CAUTION. • This general symbol is often paired with one of the symbols listed below.
	<ul style="list-style-type: none"> • PROHIBITION. • This general symbol is often paired with one of the symbols listed below.
	<ul style="list-style-type: none"> • DISPOSITION, OBLIGATION. • BEHAVIOUR, SPECIFIC ACTION. • This general symbol is often paired with one of the symbols listed below.
	<ul style="list-style-type: none"> • Refer to the manual and to the technical documentation. • Carry out the ordinary maintenance.
	<ul style="list-style-type: none"> • Risk of cutting hands or fingers. • Motor fan, belts, rotating parts.
	<ul style="list-style-type: none"> • Risk of chemical burning to fingers or hands. • Hazardous or corrosive liquids.
	<ul style="list-style-type: none"> • Risk of cutting or crushing hands or fingers. • Do not remove safety devices. • Rotating parts.
	<ul style="list-style-type: none"> • Excessive load risk. • Do not lift manually.

SYMBOL	DESCRIPTION
	<ul style="list-style-type: none"> • Fire risk. • Emergency exit
	<ul style="list-style-type: none"> • Risk of burning. • Do not touch. • Hot surface
	<ul style="list-style-type: none"> • Risk of cutting or crushing hands. • Do not remove safety devices.
	<ul style="list-style-type: none"> • Risk of cutting or crushing feet. • Do not remove safety devices. • Rotating parts.
	<ul style="list-style-type: none"> • Suspended loads risk. • Suspended loads in movement.
	<ul style="list-style-type: none"> • Risk of explosion of the hydraulic hoses. • Pipes subjected to high pressure.
	<ul style="list-style-type: none"> • Risk of falling. • Do not lean! It is dangerous.
	<ul style="list-style-type: none"> • Risk of environmental pollution.
	<ul style="list-style-type: none"> • Keep a safe distance.
	<ul style="list-style-type: none"> • Risk of crushing the body.

SYMBOL	DESCRIPTION
	<ul style="list-style-type: none"> • Carry out the maintenance activities.
	<ul style="list-style-type: none"> • Poisonous substances.
	<ul style="list-style-type: none"> • Do not touch. • Hot surface.
	<ul style="list-style-type: none"> • Suspended loads.
	<ul style="list-style-type: none"> • Rotating parts.
	<ul style="list-style-type: none"> • Harmful or hazardous substances.
	<ul style="list-style-type: none"> • Mandatory protection of the hands.
	<ul style="list-style-type: none"> • Mandatory use of safety shoes.
	<ul style="list-style-type: none"> • Mandatory hearing protection.
	<ul style="list-style-type: none"> • Mandatory use of eye protection.

<i>SYMBOL</i>	<i>DESCRIPTION</i>
	<ul style="list-style-type: none"> • It is mandatory to check and activate the protection devices.
	<ul style="list-style-type: none"> • Mandatory protection of the body- • It is mandatory to use the prescribed safety clothing.
	<ul style="list-style-type: none"> • Mandatory protection of the face.
	<ul style="list-style-type: none"> • Mandatory protection of the head.
	<ul style="list-style-type: none"> • Mandatory use of harness or safety belt. • Use protections against the risk of falling.
	<ul style="list-style-type: none"> • Mandatory individual protection against falls.
	<ul style="list-style-type: none"> • Mandatory use of a lifting device for loads that weight more than 30 kg
	<ul style="list-style-type: none"> • The presence of at least 2 operators is mandatory
	<ul style="list-style-type: none"> • It is forbidden to carry out any adjustment or maintenance activity while the parts are still moving.
	<ul style="list-style-type: none"> • Useful tips and suggestions

C

General description.

C. General description

C.1 Description

The vacuum pumps produced by **Moro Kaiser srl** have a great tradition of reliability, long life and versatility. They are available with various flow rates, types of operation and cooling.

The principle of rotating volumetric operation with vanes ensures that high degrees of vacuum are reached and allows a vast field of application.

Industrial users of vacuum pumps require safe, constant running at a high vacuum for long periods. To satisfy this need, **Moro Kaiser srl** has developed a unique technology of liquid cooling even in the rotor, thus keeping lower temperatures inside the pump. This is to the advantage of the lubrication, the vanes and the seals, thus allowing use in harsher conditions.



Fig. C.1 - PM90T Turbo

Warnings, residual risk, precautions and responsibilities.



D. Warnings

We dedicate to “WARNINGS” a whole chapter with the purpose to underline the commitment MORO KAISER S.R.L. dedicates to “SAFETY” in all its forms and applications.

D.1 Responsibilities

- The manufacturer is responsible for the smooth operation and the security of the pump against damages to persons or properties only for manufacturing defects established by the manufacturer itself.
- No modifications or additional applications shall be made to the pump, without a previous written authorization by MORO KAISER S.R.L.. All responsibilities are excluded if there have been unauthorized maintenance activities or replacement of parts, unauthorized modifications or any activity made against the instructions supplied.
- The company does not assume any hidden defects of the vehicle which could cause damage or injury to persons, animals or things.

D.2 Designated use

The vacuum pump, or decompressor, is intended for the suction and compression of clean air to produce vacuum or pressure in normal atmospheric air.



The pump must not be used for purpose different from the above mentioned. An improper use of the pump could cause damages to persons and properties.

Every user shall be aware that by not following the instructions stated in this booklet, could cause damages to persons or to the pump.

D.3 Staff training



All the people using and maintaining the pump, or are in some way responsible, must:

- be properly educated about the rules, regulations and behaviors regarding safety
- be properly educated about the legal background, where the pump is located.
- be informed of the residual risks.
- read and understand the information contained in this manual before starting any use of the pump.

D.4 General warnings about safety

D.4.1 Norms and laws



- You must observe the law, comply with the safety regulations in force and the instructions of the manufacturer.

D.4.2 Safety devices, protection and signaling



- All safety, protection and signaling devices must be active and functioning and their reliability must be ensured.
 - All safety components must be maintained in good working order.
 - Do not inhibit the safety devices.
 - Do not remove the safety guards.
 - Guards and safety devices should not be removed except for maintenance needs, by taking all the means necessary to limit the dangers arising therefrom, all under the supervision of the safety director of the pump or of the system.
 - Safety signs must be relevant, visible and in good condition.
 - All damaged or illegible plates and safety labels must be replaced.

D.4.3 P.P.E. Personal Protective Equipment



- Use all PPE (personal protective equipment) required by the rules.
- All PPE must be appropriate and in accordance with the risk situations.

D.4.4 General rules of behaviour



- Do not use the pump under the influence of alcohol, narcotics, drugs or psychotropic substances which may result in the decrease of attention or sleepiness keeping in mind that a careful and responsible conduct is the basis for the prevention of accidents at work.



- Never stand within the range of the pump.
 - Make sure that there are no people, animals or things within the range of the pump.
 - Always keep a safe distance. The safety distance is among the most effective standards of conduct for health preservation.



- Do not operate on moving parts. Before performing any maintenance operation:
 - turn off the pump.
 - if available, remove the ignition key of the system.
 - make sure that the pump can not be accidentally restarted.
 - see the reference documentation.
- Clothing must be worn correctly,
 - loose clothes may get caught on moving parts.
 - metal objects such as watches, bracelets, necklaces and rings can lead to short circuits.

D.4.5 Work environment, general indications

The working area must be made safe.

- **Noise.** Limit levels and times of exposure to noise in accordance with the provisions of the safety rules. Take all necessary precautions for reducing noise and use personal protective devices.

- **Lighting and visibility.** The working environment must have adequate lighting. Avoid to operate in reduced visibility situations.
- **Atmosphere.** The working environment must be properly ventilated. Dusts, fumes, mists, gases, and more generally harmful airborne toxic pollutant materials must not be present in sufficient concentration in order to cause harm. Do not operate in situations of hazardous atmospheres. Use personal protective devices.
- **Hazardous substances.** Keep the working environment free from hazardous substances. Substances such as vacuum pump cooling liquid, fuels, hydraulic oils, engine oils, exhaust oils, can be absorbed by the human body by ingestion, contact or inhalation and cause damage to health.
- **Functional areas.** The floors of the working environment and, more generally, all the functional areas, must be fixed, stable, non-slippery and free of bumps, holes or dangerous inclined planes.
- **Electricity.** The electrical devices and installations must be adequate, in perfect condition and comply with the regulations. Particular attention must be paid to grounding systems and static charges protective devices. Use personal protective devices.
- **High pressures.** Pipes, fittings, tanks, and more generally any system or component subjected to high pressure must be up to standard, correctly sized and properly shielded in order to protect who operates in the working area.
- **Fire hazard.** Limit the presence of flammable substances and materials in the working area as much as possible. The fire protection systems must be up to standard, adequate and in perfect conditions. Use personal protective devices.
- **Vibrations.** Limit time and level of exposure to vibrations in accordance with the provisions of the safety rules. Take all necessary precautions for reducing the vibrations and use personal protective devices.
- **Electromagnetic fields.** Limit time and level of exposure to electromagnetic fields in accordance with the provisions of the safety rules. Take all necessary precautions for reducing their intensity and extent and use personal protective devices.

D.5 Dangers

The following DANGER indications are related to the **vacuum pumps** only and each one is equally important.

D.5.6 Dangers due to operating procedures:

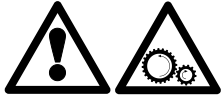

- Pay maximum attention to the movements of all mechanical devices, and make sure there are no persons nor animals within their working radius.
- Do not remove, for any reasons, safety fixtures installed in the pump for security purposes.
- Follow accurately all safety norms in force.

Noise and Vibration



- The vacuum pump is a source of vibrations and noise.
 - Protect your hearing.
 - Protect yourself from vibration.

High temperatures



- The vacuum pump can reach high temperatures.
 - Never touch the pump with your hands: danger of burning.
 - Use gloves to operate the switch valve.

High speed air. Air under pressure

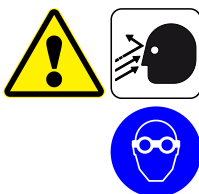

- Air flow at suction and discharge ports reaches high velocities and may eject materials and objects.
 - Protect eyes and face.
 - Move materials and objects away from the vacuum pump airflow.

Transport and handling



- The vacuum pump is very heavy. An improperly positioned or improperly packed vacuum pump may tip over or fall, creating very serious hazards for operators.
 - Protect limbs at risk of crushing.
 - Always use suitable lifting gear.

- Use only the appropriate holes or eyebolts to move the pump.
- Make sure packaging is appropriate and in perfect condition.

Dangerous substances



- The vacuum pump may contain oils and other liquids necessary for its operation, which may be sprayed into the air in case of poor maintenance or breakdown.
 - Protect your eyes and skin to avoid contact with hazardous substances.
 - Protect your respiratory tract to prevent inhalation of hazardous substances.



- The vacuum pump may contain oils and other liquids necessary for operation, which may leak and make walking surfaces slippery in case of poor maintenance or failure.
 - Protect your skin to avoid contact with hazardous substances.
 - Wear appropriate non-slip footwear.

Flammable substances



- Do not underestimate the risk of fire generated by oils and fuels normally used in the operation and maintenance of the vacuum pump.
 - Flammable liquids are more likely to ignite when they come in contact with hot surfaces
 - Immediately repair any spillage of oil, fuel, or other flammable substances
 - Fire-fighting equipment must be adequate and in good working order

Potentially explosive atmosphere



- During normal operation, the vacuum pump compresses the fluid it carries, raising its temperature.
 - Do not use the vacuum pump in potentially explosive atmospheres.
 - The vacuum pump, or decompressor, is intended for the suction and compression of clean air.

Start-up



- The vacuum pump can be equipped with a diverter that allows to reverse the direction of the air flow.
 - Before starting the vacuum pump, check that the flow diverter is set correctly so as not to create a hazardous situation.

Testing and extraordinary maintenance



- For testing and in situations of extraordinary maintenance, it may be necessary to disconnect the pipes from the suction and discharge ports, thus leaving the rotating parts inside the vacuum pump accessible and generating an important risk situation.
 - Testing and extraordinary maintenance must be carried out by qualified personnel and workshops.
 - Do not approach moving parts. The risk of entrainment is high.
 - Do not approach inlet or discharge ports. There is a high risk of limbs, hair, clothing or other items being sucked into the pump.



- Whenever you have to work in a hazardous situation, you must be supervised by the person in charge of the pump.
 - Restore guards and safety devices as soon as possible.
 - Personnel involved should be trained on hazardous conditions.

D.5.7 Residual hazards and unsafe conditions for the pump.

Noise and Vibration



- The vacuum pump is a source of vibration that can be transmitted to the equipment to which it is connected and affect the effectiveness of the fasteners.
 - Check the anchoring systems regularly. Screws, bolts, hooks and so on can become loose and create dangerous situations.



- Check that the decompressor does not generate abnormal noises and vibrations compared to those expected during normal operation.

- Abnormal noises and vibrations indicate malfunction, stop the pump and contact qualified personnel for repairs immediately.

High temperatures



- Excessive temperature can damage the vacuum pump.
 - Check regularly that the decompressor is operating within the allowable temperature limits.
 - Exceeding the maximum temperature limits can cause severe damage to the decompressor blades, seals and rotating devices.
- In maximum vacuum operation, the airflow through the decompressor and cooling it is minimal.
 - Do not exceed the allowable vacuum degree/time limits.
 - Make sure there are no obstructions in the intake and exhaust lines.
- For higher performance, some models are equipped with a liquid cooling system.
 - Check that the liquid cooling system is in perfect working order.

Storage, transport and handling

- A vacuum pump that is not properly hooked, improperly positioned or with inadequate or defective packaging may tip over or fall and be damaged
 - Always use proper lifting and carrying pump.
 - Packaging must be suitable for the purpose and in perfect condition. Defective packaging may collapse under the weight of the decompressor or the packages it is designed to support.
 - Only use the appropriate holes or eyebolts to move the pump. An improperly attached pump may be damaged during movement.
 - During transport, the vacuum pump must be securely locked, must not be able to slip or jerk to avoid damage.
 - Vacuum pump must be properly treated when they are to be stored for long periods to avoid oxidation damage.

- Do not tip the vacuum pump.

Foreign bodies, materials and harmful substances

- In addition to air, no liquids, dust, dusty materials or other materials of any kind should enter the vacuum pump.
 - Liquids, dust and foreign bodies inside the vacuum pump can cause breakage.
 - Equip the system with a suitable filtering system.
 - In the presence of liquids, equip the system with overflow safety valves.

D.5.8 Dangers coming from general maintenance:

- The equipment must be used by well-trained personnel only. The pump shall be maintained following the instructions provided by the Manufacturer and shall be carried out by a qualified and well-trained personnel only.

The maintenance personnel must use all possible means for the personal safety according to the safety rules of their own country. In general they should avoid to get in touch with substances that arouse dangers to themselves.

Some examples:

- Diesel fuel is irritating for eyes and skin.
- Hydraulic oil is also irritating for eyes and skin.
- Used oil contains some dangerous substances for your health.
- Do not use large or unbuttoned clothing near turning mechanical devices. Keep hands and hairs away from moving part like fans, belts, etc.
- Do not operate on moving parts. Always stop the vehicle engine and remove the key from the vehicle keyboard.
- Remove wrist watches, rings, necklace chains, and bracelets before starting any maintenance job. They could get jammed between running devices.
- Always operate in airy environment and use, if necessary, smoke stacks.

D.6 Precautions

D.6.9 When using and maintaining:



- **MAX ROTATION:** Do not exceed the maximum rotating speed indicated in the “**Performance table**”, **page 21**.



- **ROTATING SPEED:** Keep the rotating speed within the range indicated in the “**Performance table**”, **page 21**.



- **MIN ROTATION:** Do not drop below the minimum permitted engine speed (see “**Performance table**”, **page 21**).



- **PRESSIONE MAX:** Do not exceed the maximum pressure values given in the “**Performance table**”, **page 21**.



- **TEMPERATURE:** The temperature at discharge of the vacuum pump must never be more than **180°C**. If this is the case, reduce the vacuum % or the working pressure by running the pump at atmospheric pressure to allow it to cool down.



- **MAXIMUM TIME OF USE (CYCLES/MINUTES):** see “**Performance table**”, **page 21**. **WARNING:** The indicated time applies to nominal operating conditions for discontinuous use. For heavy duty or continuous use please contact **Moro Kaiser srl**.

Dimensions, technical characteristics and identification.



E. Dimensions and technical characteristics

E.1 Performance table

PERFORMANCES	[u.m.]	TURBO PM90T
1 Rotation speed (work)	rpm	1200
2 Maximum rotation speed	rpm	1350
3 Free mouth suction flow rate	m ³ /h / (cfm)	731 / (430)
4 Flow rate at 15 In Hg (50% vacuum)	m ³ /h / (cfm)	590 / (347)
5 Nominal Vacuum	% / (In Hg)	80 / (23.9)
6 Maximum Vacuum	% / (In Hg)	95 / (28.4)
7 Nominal Pressure	bar abs / [barg] / (psig)	1.8 / [0.8] / (11.6)
8 Maximum Pressure	bar abs / [barg] / (psig)	3.0 / [2.0] / (29)
9 Power input at maximum pressure	kW / (HP)	27.5 / (37.4)
10 Power input at rated vacuum	kW / (HP)	9.8 / (13.3)
11 Power consumption at 15 In Hg (50% vacuum)	kW / (HP)	7.9 / (10.7)
12 Minimum oil consumption at working speed	gr/h	154
13 Tank capacity	Lt / (Quarts)	4 / (4.2)
14 Weight	kg / (lb)	213 / (470)
15 Sound pressure level	dB-A	78
16 Maximum time of use in nominal condition and max rotation (1350 rpm)	min.	1
17 Maximum time of use in nominal condition and working rotation (1200 rpm)	min.	40



WARNING!

It is strictly forbidden to operate the pump under pressure at the maximum rotation speed.



WARNING!

Times shown are for rated operating conditions for discontinuous use. For heavy-duty or continuous use, please contact **Moro Kaiser srl.**

E.2 Characteristics and dimensions

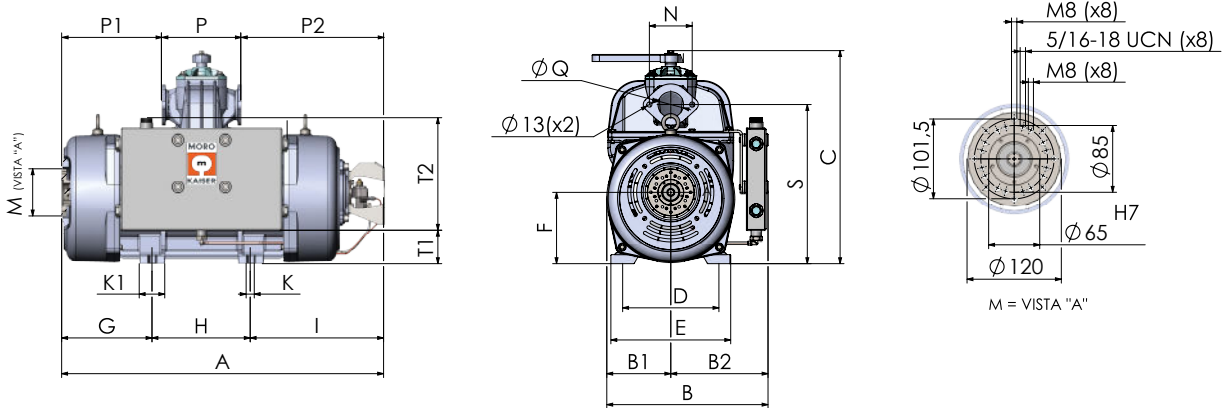

Fig. E.1 - Pumps dimensions

	A	B	B1	B2	C	D	E	F	G	H	I	K	K1	N	P	P1	P2	Q	S	T1	T2
mm	819.5	410.5	163	247.5	542	245	305	181.5	230	250	339.5	16	65	109	202	254	363.5	76-80	405	85	283.5
in	32.3	16.2	6.4	9.7	21.3	9.6	12.0	7.1	9.1	9.8	13.4	0.6	2.6	4.3	8.0	10.0	14.3	3	15.9	3.3	11.3

E.3 Identification

The identification plate with the main technical features is positioned on the vacuum pump and is always visible.

Make sure when purchasing the product that it has an identification plate. If this is not the case, inform the manufacturer and/or retailer immediately. Appliances without an identification plate must not be used or the manufacturer will no longer be liable. Unlabeled products should be considered anonymous and potentially hazardous.

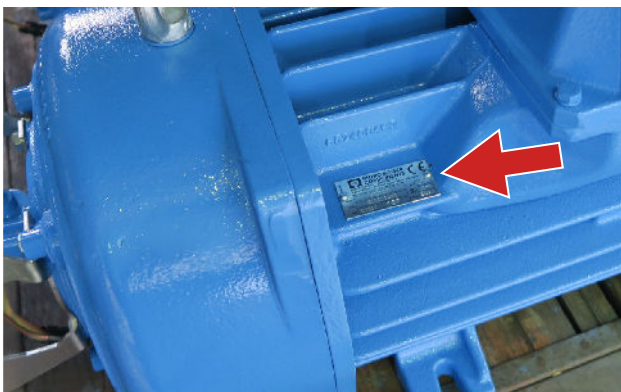

Fig. E.2 - Label position on the pump

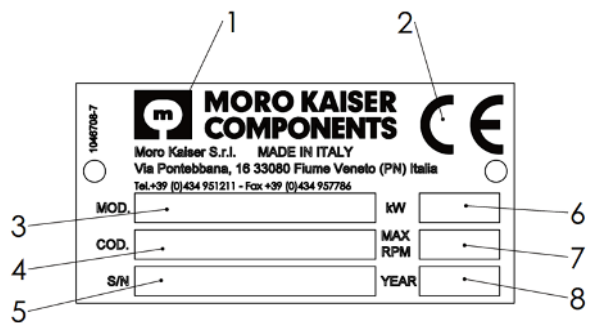

Fig. E.3 - Identification plate

1	Manufacturer	5	Serial number
2	"CE" Mark	6	Max absorbed power
3	Model	7	Max rotation speed (rpm)
4	Model code number	8	Year of construction



Installation of the pump.

G. Installation of the pump

G.1 Packing and lifting



All the elements necessary for the correct installation of the vacuum pump can be found in Moro Kaiser price list.

Bags, boxes, nails and any other part of the packaging must not be left within the reach of children.

Check on receipt

All accessories listed on the transport document must be checked on arrival to ensure they are in perfect working order. The vacuum pump must not have been damaged during transport. Manually check that the shaft rotates easily.

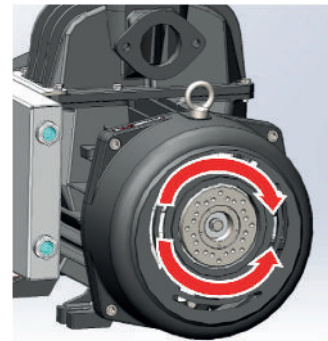

Fig. G.1 - Check on receipt

Lifting

Lift the vacuum pump using only the pair of eyebolts provided. When the pump needs to be lowered to rest, perform this maneuver very slowly. To check the weight, refer to the "Performance table", page 21.



WARNING!

Do not damage the oil lines during lifting.



WARNING!

Always use suitable lifting gear to move the pump.

The vacuum pump is equipped with special eyebolts for attaching lifting chains. The lifting hooks and chains must also be suitable for the purpose.

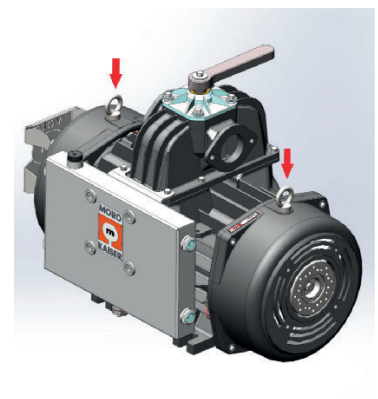

Fig. G.2 - Lifting

G.2 Setup

Mounting the vacuum pump

The mounting location on the vehicle must be easily accessible and protected from objects that could damage the vacuum pump.



WARNING!

Provide sufficient space for the pump and all pipes of the suction and discharge system and to allow free circulation of the cooling air.

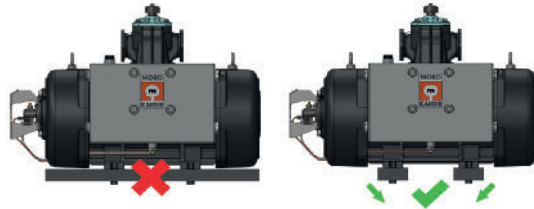

Fig. G.3 - Mounting

Aligning the vacuum pump

The vacuum pump is usually attached to the vehicle frame or the vacuum pump bracket. The direction of rotation of the drive must coincide with the direction of the arrow on the pump. Avoid blows to the pulley, driveshaft and coupling. Do not apply random forces during assembly. Align the couplings exactly.

Avoid accidental collisions.



WARNING!

The vacuum pump must be mounted horizontally, 5° maximum inclination is tolerated.

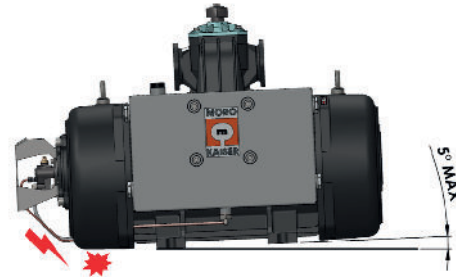

Fig. G.4 - Alignment and rotation plate

Transmission elements

Transmission can be via cardan shaft, pulley or flexible coupling.



WARNING!

The transmission elements must not be coupled with hammer blows.

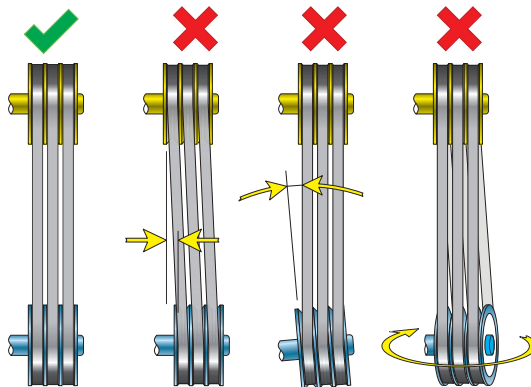

Fig. G.5 - Pulleys alignment

The pulley can be directly connected to the vacuum pump shaft, taking special care in its assembly:

- The axes must be parallel to avoid a different load on the belts.
- The pulleys must be aligned to avoid an excessive axial load on the vacuum pump shaft.



WARNING!

Use the original **Moro Kaiser srl** pulley kit specially designed with three grooves $D_p=153\text{mm}$ for V-belt type B or SPB. (For other types of pulleys use belts with SPA, SPX profiles).



WARNING!

Do not use the pump pulley as a return pulley for other drives.

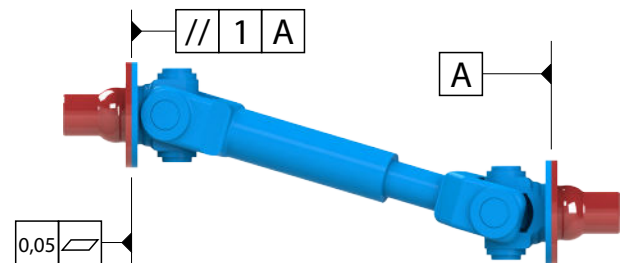

Fig. G.6 - Cardan

When installing with a cardan shaft, it is important that the design of the hub couplings and their installation be particularly careful.

- The cardan-decompressor and cardan-engine coupling flanges must be perfectly parallel.
- The maximum misalignment of the cardan crosses must generate an angle " α " of less than 10° .

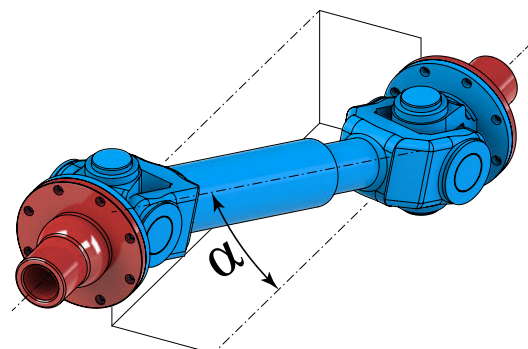

Fig. G.7 - Cardan alignment

In installations with driven shaft and driven shaft on axis, an elastic element must be interposed. Direct drives, without elastic coupling, are not approved by our technical office.

- Elastic torsion and interlocking couplings compensate axial angular misalignment " β " and radial misalignment " δ " within specified tolerances;

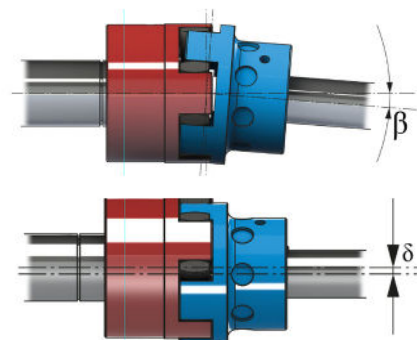

Fig. G.8 - Elastic coupling

- The elastic spacer ring absorbs shocks and torsional vibrations. The elastic spacer ring absorbs torsional shocks and vibrations. The supplier's instructions for the selection and installation of the elastic coupling must be strictly observed.

Suction hoses

Avoid installing tubing that corrodes internally.

Upon installation, the piping should be cleaned internally; carefully remove any welding debris, filings, rust, or other foreign matter.

Check valve

A special check valve is installed in the vacuum pump that closes when the pump is stopped, thus preventing the return of fluids to the tank and the reverse rotation of the pump.

Prevention of suction of liquids and foreign bodies

The vacuum pump must be protected against the suction of liquids or foreign bodies with two automatically closing float safety valves (primary and secondary) and a safety filter.



Any suction of liquids, solids, powdery or foreign bodies may cause the breakage of the vanes, the shaft and the pump body.

For this purpose **Moro Kaiser srl** has developed a double protection system (see **Fig. G.14, page 28**).

Four-way valve (Diverter valve)

The four-way valve allows the tank to communicate with the suction inlet or the pressure inlet of the vacuum pump. It allows to create both vacuum and pressure inside the tank. The valve is controlled by the lever on the top of the pump.



WARNING!
Operate the diverter valve only with gloves.



Fig. G.9 - Four-ways valve

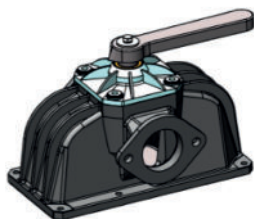

Fig. G.10 - Manual diverter group



Fig. G.11 - Pneumatic diverter group

Four-ways valve screw adjustment

The diverter group is supplied with the adjustment screw already set. If you need to adjust it, follow the instructions below.



WARNING!

Lightening the diverter lever too much may cause a drop in the performance of the pump and a drop in the vacuum level in the tank.

- Unscrew 6 hex screws and remove the manifold group.
- Temporarily support the oil tank. If this proves difficult:
 - a) empty the oil from the tank.
 - b) disconnect the oil line at the bottom of the tank.
 - c) remove the tank.
- Remove and replace the sealing gasket **pos.3 Fig. G.12**.
- Use a 6mm Allen wrench to hold down the adjustment screw **pos.4 Fig. G.13**.
- With a 19 mm wrench, loosen the locking nut **pos.5 Fig. G.13**.
- Now operate on the adjustment screw **pos.4 Fig. G.13** by making minimum movements, bearing in mind that by screwing it in, the strain on the diverter is reduced while by unscrewing it, the strain increases. Check the hardness of the movement by moving the lever (manual diverter **Fig. G.10**) or observing the movement (pneumatic diverter **Fig. G.11**).
- When the adjustment is complete, maintain the position of the adjustment screw **pos.4 Fig. G.13** with an Allen wrench and tighten the locking nut.



WARNING!

During installation, provide sufficient space for air circulation around the vacuum pump to allow it to cool.

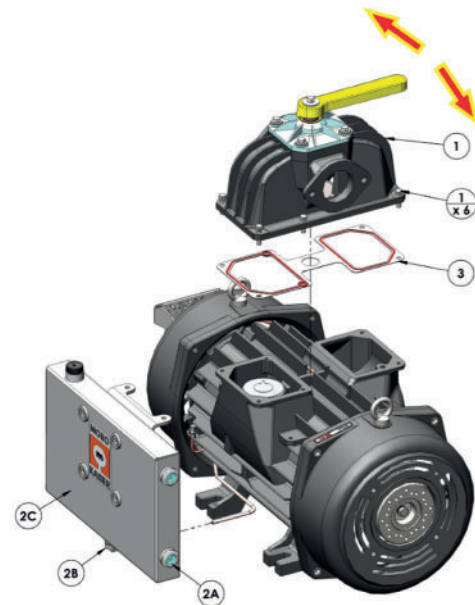

Fig. G.12 - Four-ways valve screw adjustment

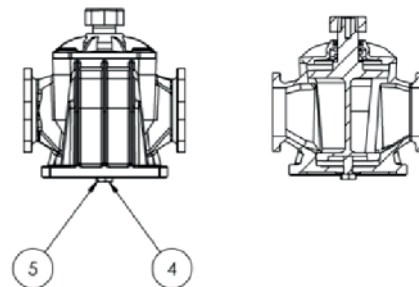

Fig. G.13 - Four-ways valve screw adjustment

G.3 Plant diagrams

G.3.1 Vacuum system diagram

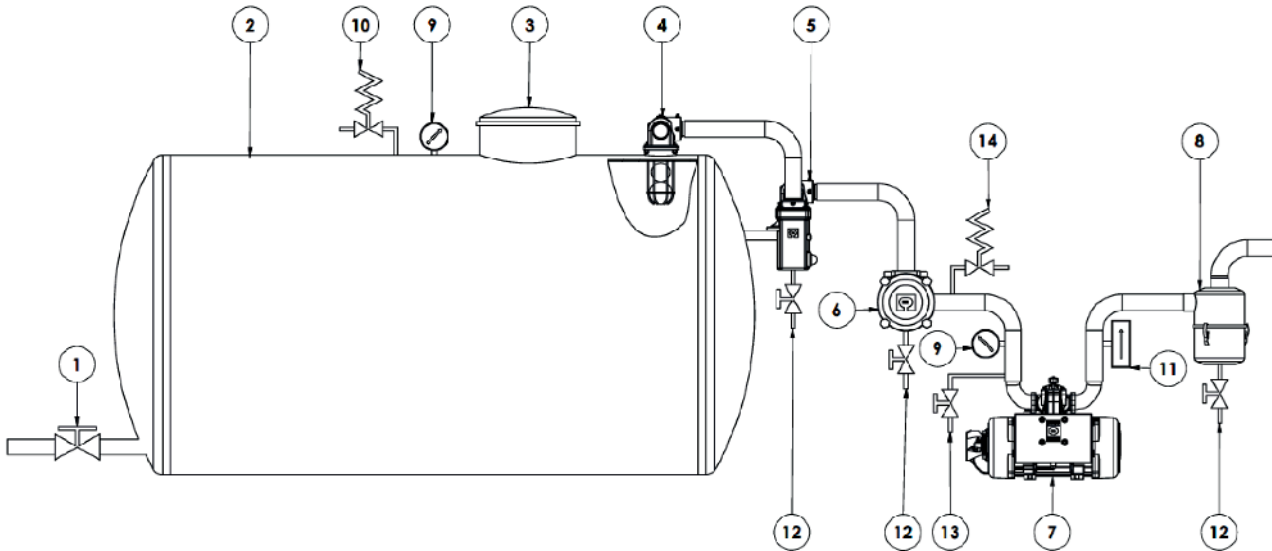

Fig. G.14 - Vacuum system diagram

1	Suction pipe with gate valve	8	Oil collection filter and silencer
2	Tank	9	Pressure gauge (-1 / +3 barg)
3	Manhole	10	Pressure relief valve (+0.8 barg)
4	Primary filter with float valve	11	Thermostat (0 / + 200 °C) (optional)
5	Secondary filter with float valve	12	Drainages (3/8" - 1")
6	Safety filter	13	Gate valve for pump flushing
7	Vacuum pump	14	Vacuum breaker valve (-0.8 barg)



WARNING!

The main hoses of the vacuum system must have an internal diameter of at least 3".



WARNING!

The optional thermostat (**pos.11 Fig. G.14**) must be installed directly downstream of the pump (max. 50 mm distance).

G.3.2 Hydraulic motor system diagram

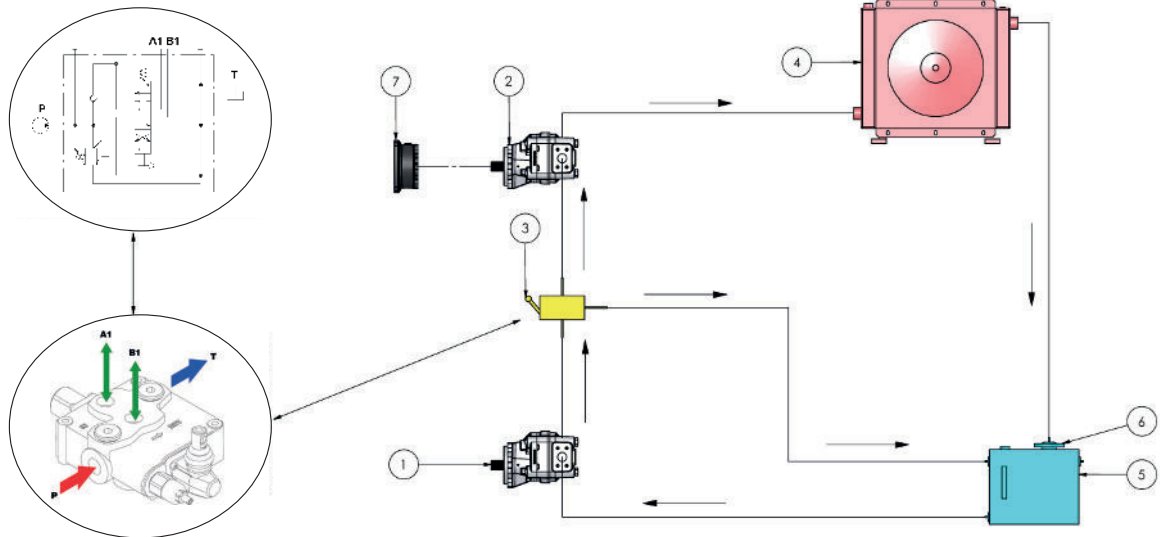

Fig. G.15 - Hydraulic motor system diagram

1	Hydraulic pump
2	Hydraulic motor
3	Distributor
4	Heat exchanger (optional)
5	Oil tank
6	Oil filter
7	Hydraulic motor support

H

Start-up, put into operation.

H. Start-up, put into operation

H.1 Lubrication



The vacuum pump is supplied without oil. Refill before use. See "Oil table", page 32.

Start-up

Check the disposable oil level of the vacuum pump on a daily basis via the sight glasses on the front and rear of the oil tank.

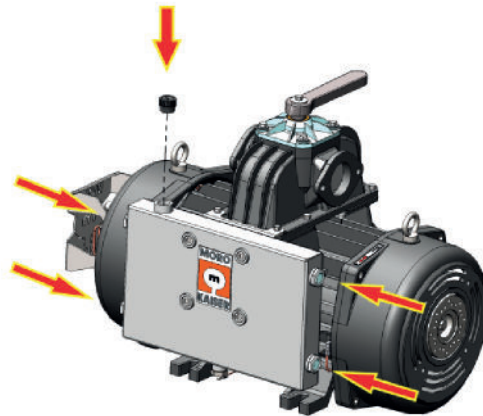

Fig. H.1 - Lubrication

Additional lubrication

For extremely heavy-duty use, additional lubrication is recommended by installing an additional external reservoir connected to the flushing valve on the pump suction line.

Slightly open the tap and allow approximately $0,2 \div 0,3 \text{ kg/h}$ of oil to flow freely through the pump, then close the valve again.

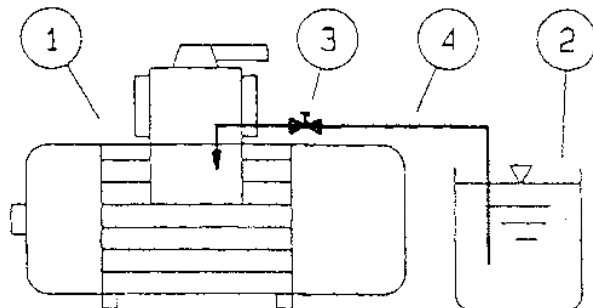

Fig. H.2 - Additional lubrication

1	Vacuum pump
2	Additional reservoir
3	Flushing valve (pos.13 Fig. G.14)
4	Hose

Automatic oil pump adjustment



WARNING!

The vacuum pump is supplied with a calibrated oil pump. See "Oil table", page 32.

If it is necessary to vary the oil flow rate supplied to the vacuum pump, follow the following instructions:

- Remove the cover **pos.1 Fig. H.3**.
- Use the screwdriver **pos.5 Fig. H.3** in the spanner **pos.4 Fig. H.3** and insert it on the register **pos.3 Fig. H.3** and locking nut **pos.2 Fig. H.3**.
- While holding the register **pos.3 Fig. H.3** steady, release the blocking nut **pos.2 Fig. H.3**.
- Operate on the adjuster with the screwdriver, bearing in mind that:
 - **tightening** decreases the oil flow rate.
 - **unscrewing** increases the oil flow rate.
- When the adjustment has been completed, hold the adjuster still with the screwdriver, tighten the locking nut and refit the cover.
- Each half turn of the adjuster gives **+ 40 gr/h** to the working rotation speed. See "Performance table", page 21.

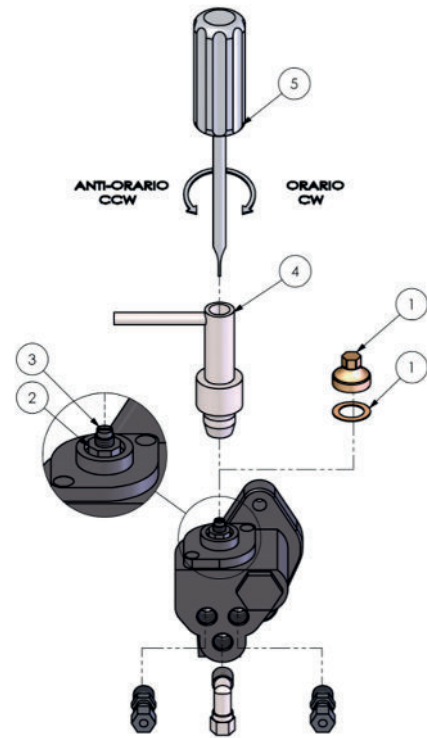

Fig. H.3 - Oil pump adjustment

If the starting reference is lost and the initial factory setting is to be restored, proceed as follows:

- Fully screw in the adjuster **pos.3 Fig. H.3**.
- Unscrew the register by **3+3/4 turns**.
- Now, the oil pump will supply the vacuum pump with the minimum setting shown in the "Performance table", page 21 at the nominal working speed.



WARNING!

It is absolutely forbidden to reduce the minimum oil quantity given in the "Performance table", page 21.

H.1.1 Oil table

SUMMER - SAE 40 (ISO VG 150)
WINTER - SAE 30 (ISO VG 100)
WINTER under -10°C / 14° F - SAE 20 (ISO VG 46)

Use extreme caution with extremely low temperatures; if necessary, contact an authorised dealer or **Moro Kaiser srl**.



WARNING!

Do not use transmission oil - used oil - hydraulic oil - vegetable oil - gear oil - brake oil.

COMPARATIVE TABLE OF LEADING MINERAL OIL BRANDS								
	ESSO	SHELL	MOBIL	AGIP ENI	ROLOIL	TEXACO	CASTROL	API
Sae 20 - Iso VG 46	Nuto 46	Morlina 46	Nuto H 46	Acer 46	Stelvio 10W20	Rando HD 46	Aircol PD 46	Compressor Oil 46
Sae 30 - Iso VG 100	Nuto 100	Morlina 100	Nuto H 100	Acer 100	Stelvio HD30	Rando HD 100	Aircol PD 100	Compressor Oil 100
Sae 40 - Iso VG 150	Nuto 150	Morlina 150	Nuto H 150	Acer 150	Stelvio HD40	Rando HD 150	Aircol PD 150	Compressor Oil 150

H.2 System put into operation

- Ensure that the level of disposable oil in the vacuum pump tank is never below the indicated minimum; refill if necessary;
- Open all shutters and valves;
- Start the vacuum pump slowly and briefly (**approx 300 giri/min**) to check the direction of rotation.



WARNING!

Check that the direction of rotation is as indicated on the arrow on the pump. If not, contact an authorised dealer or **Moro Kaiser srl**.

Check whether vacuum or pressure is produced by the diverter valve by reading the pressure gauge (see "**Plant diagrams**", page 28). After checking this, the vacuum pump is ready for operation.



WARNING!

Never work with a speed lower than **950÷960 rpm** to avoid hammering and early wear of the pump body.

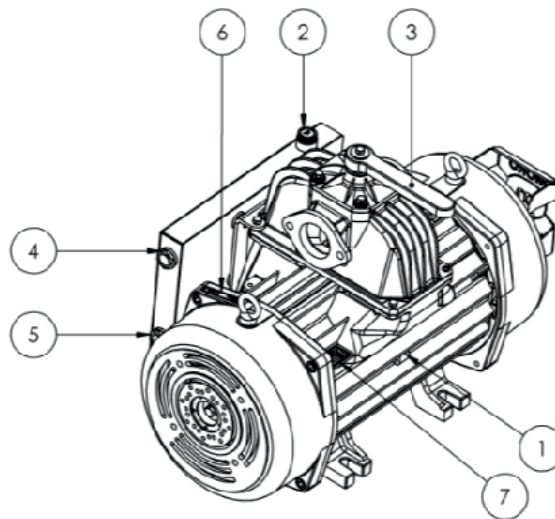

Fig. H.4 - Vacuum pump parts identification

1	Vane wear control hole
2	Disposable lubrication oil filler cap
3	Diverter valve actuation lever
4	Max oil level
5	Min oil level
6	Pump rotation arrow plate
7	Identification plate

H.3 Change of pump setup for user requirements - Procedures

H.3.2 Procedure for changing the oil tank side



WARNING!

As a standard, the oil tank is fitted on the suction side (since it's cooler). Moving it to the exhaust side can lead to increases in oil and vacuum pump temperatures. Carry this out only if strictly necessary.



The min/max level is displayed by means of sight glasses on both sides of the tank.

Phase 0010

Disconnect the oil suction pipe located under the oil tank.

- Completely empty the tank of any oil.
- To speed up the operation it is possible to unscrew one of the two MINIMUM oil level indicators (spanner ch32).
- Unscrew the head of the fitting (**pos.1 Fig. H.5**) (spanner ch10).

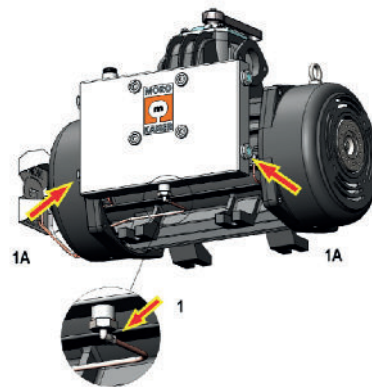

Fig. H.5 - Phase 0010

Phase 0020

- Unscrew the two M8x35 screws (**pos.1 Fig. H.6**) (spanner ch13) and remove the tank with "L" support.

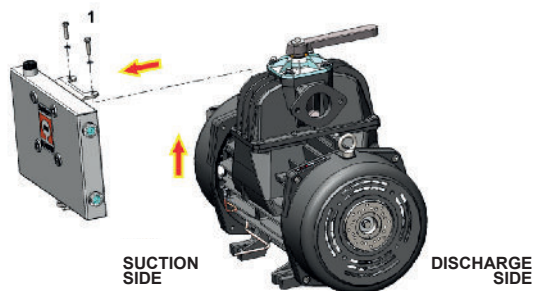

Fig. H.6 - Phase 0020

Phase 0030

- Unscrew the two M8x30 screws (**pos.1 Fig. H.7**) (spanner ch13) from the collector side (**pos.A Fig. H.7**) and reassemble them on the opposite side of the collector (**pos.B Fig. H.7**).
- Reposition the oil tank on the collector (**pos.A Fig. H.7**).
- Tighten the M8x35 screws (**pos.2 Fig. H.7**) (spanner ch13).

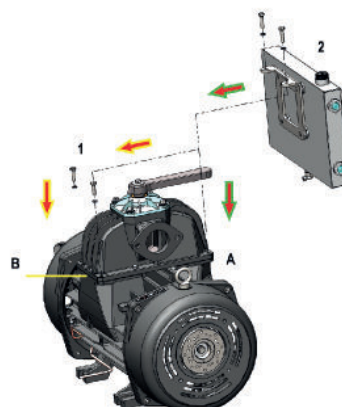

Fig. H.7 - Phase 0030

Phase 0040

- Oil tank positioned.

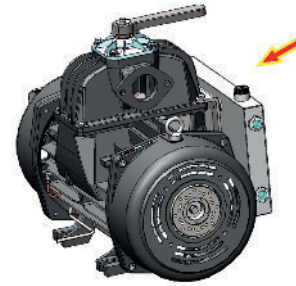

Fig. H.8 - Phase 0040

Phase 0050

- Remove the rear cover for the oil pump protection.
- Remove 4 M8x20 screws (**pos.1 Fig. H.9**) (spanners ch13).
- Remove the spiral sheath from the pipes.

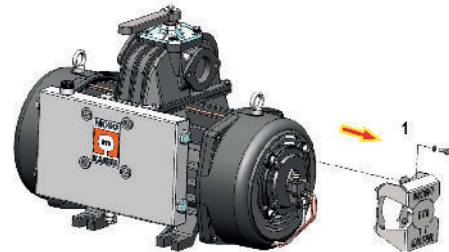

Fig. H.9 - Phase 0050

Phase 0060

- Unscrew the head of the fitting (**pos.1 Fig. H.10**) (spanner ch10).
- The fitting heads remain on the ends of the pipes (**pos.2 Fig. H.10**).
- Straighten the copper pipes as much as possible except for the last bend (space for the union heads) (**pos.3 Fig. H.10**).
- Then pass the pipes with union heads through the highlighted slot on the rear fan cover (**pos.4 Fig. H.10**).

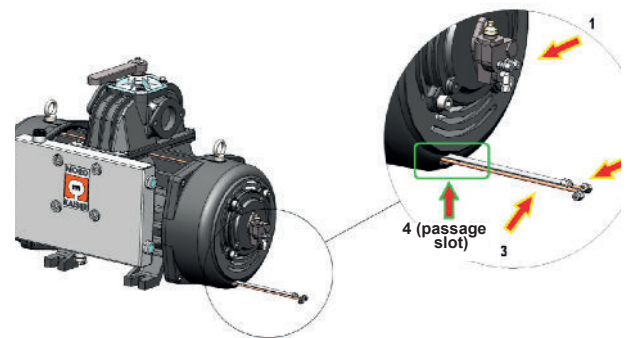

Fig. H.10 - Phase 0060

Phase 0070

- Remove 4 M12x25 screws (**pos.3 Fig. H.11**) (Allen key 10).
- Remove the rear fan cover (**pos.1 Fig. H.11**) without removing any screwed parts (**pos.4A - 4B Fig. H.11**).
- Pay attention to the slightly difficult passage of the pipes through the slot (**pos.2 Fig. H.11**).

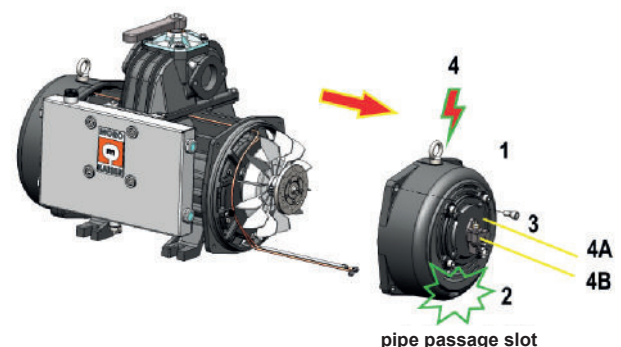

Fig. H.11 - Phase 0070

Phase 0080

- Remove the oil suction pipe, turn it 180° and reposition it on the opposite side (**pos.2 Fig. H.12**).
- Reconnect the pipe (**pos.2 Fig. H.12**) (spanner ch10) to the oil tank connection (**pos.1 Fig. H.12**).
- If necessary, adjust the plastic oil suction pipe by loosening the intermediate fitting (spanner ch 12) (**pos.3 Fig. H.12**).

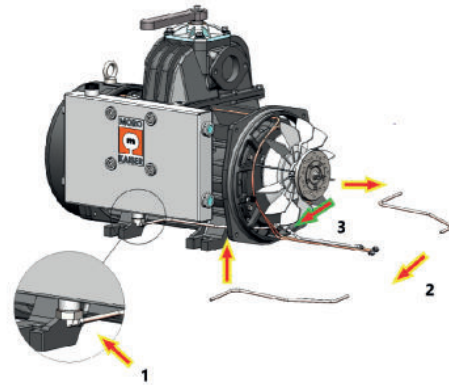

Fig. H.12 - Phase 0080

Phase 0090

- Now proceed to reassemble the vacuum pump, following all the steps described above in reverse order.
- Pay attention during reassembly. Make sure that the coupling of the oil pump fits into the keyway of the drive flange.
- If necessary, fit the oil pump last to facilitate reassembly.

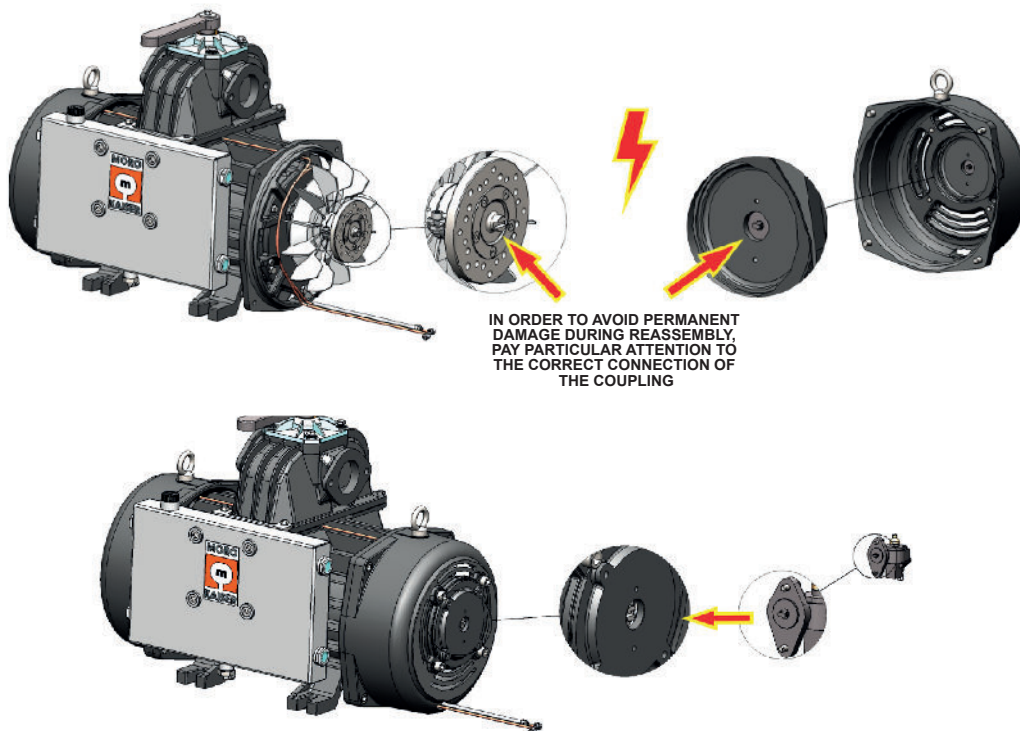

Fig. H.13 - Phase 0090

H.3.3 Procedure for changing vacuum pump rotation



WARNING!

To avoid misunderstandings, all parts removed from the pump must remain on the disassembly side. Do not swap parts from the front side with the rear side and vice versa.

Replace all disassembled seals and any damaged seals.



WARNING!

Do not invert parts

Phase 0010

- Remove 4 M12x25 screws (**pos.1 Fig. H.14**) (chiave brugola 10) and remove the front fan cover (**pos.2 Fig. H.14**).

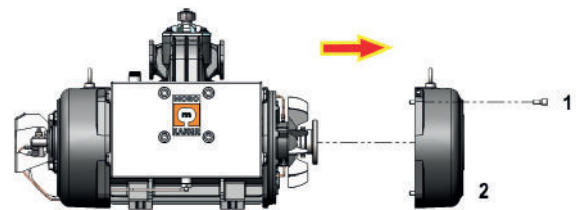

Fig. H.14 - Phase 0010

Phase 0020

- Remove the rear cover for the oil pump protection.
- Remove 4 M8x20 screws (**pos.1 Fig. H.15**) (spanner ch13).
- Remove the spiral sheath from the pipes.

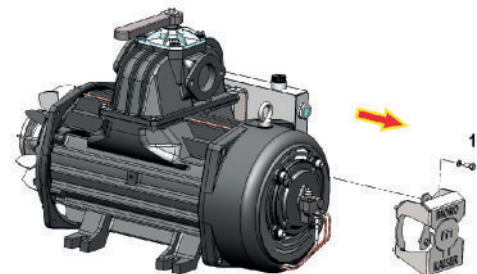

Fig. H.15 - Phase 0020

Phase 0030

- Unscrew the head of the fitting (**pos.1 Fig. H.16**) (spanner ch10).
- The fitting heads remain on the ends of the pipes (**pos.2 Fig. H.16**).
- Straighten the copper pipes as much as possible except for the last bend (space for the union heads) (**pos.3 Fig. H.16**).
- Then pass the pipes with union heads through the highlighted slot on the rear fan cover (**pos.4 Fig. H.16**).

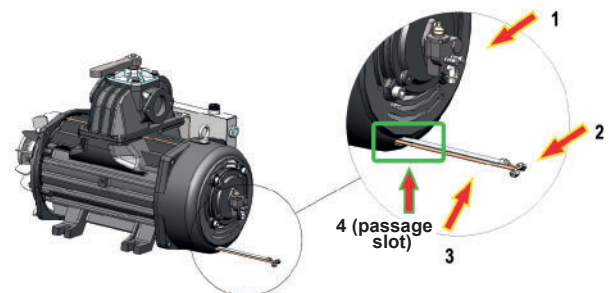

Fig. H.16 - Phase 0030

Phase 0040

- Remove 4 M12x25 screws (**pos.3 Fig. H.17**) (Allen key 10).
- Remove the rear fan cover (**pos.1 Fig. H.17**) support flange and oil pump (**pos. 4A-4B Fig. H.17**).
- Pay attention to the slightly difficult passage of the pipes through the slot (**pos.2 Fig. H.17**).
- Warning: the oil pump (**pos. 4B Fig. H.17**) must be replaced from left to right or vice versa. For codes see exploded view tables.

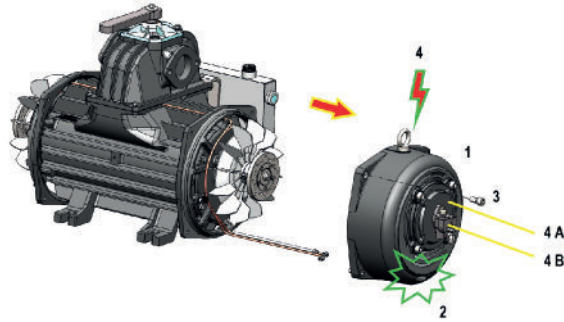

Fig. H.17 - Phase 0040

Phase 0050

- Remove nr. 5 screws M5x16 (**pos.1 Fig. H.18**) (Allen key 6).
- Remove the oil pump drive flange (**pos.3 Fig. H.18**), if necessary, use a screwdriver to pry behind the flange stop. (**pos.2 Fig. H.18**).

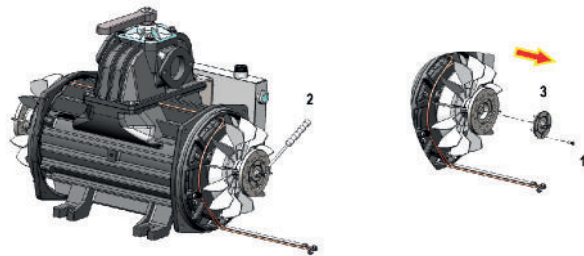

Fig. H.18 - Phase 0050

Phase 0060

- Unscrew the heads of the oil pipe fittings (**pos.1-2-3 Fig. H.19**) (spanner ch10).
- The union heads remain on the ends of the pipes.

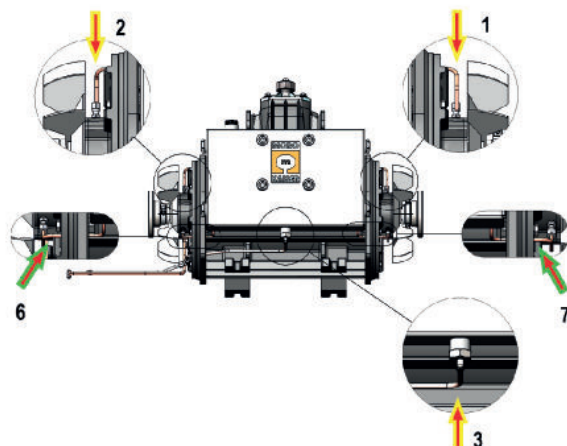

Fig. H.19 - Phase 0060 - part 01

- Straighten the oil pipe on the front bearing side (**pos.1A Fig. H.20**) (only the 90° bend) so that it can be removed from the flange slot.
- Remove the hose clamp, unscrew the M6x10 screw (**pos.4 Fig. H.21**) (Allen key 5).
- Remove the oil pipes in question (**pos.5 Fig. H.22**) from the vacuum pump.
- The oil pipes (**pos.6 and 7 Fig. H.19**) remain in their current position. No intervention is required.

Phase 0070

- Turn the vacuum pump 180° (see **Fig. H.23**).

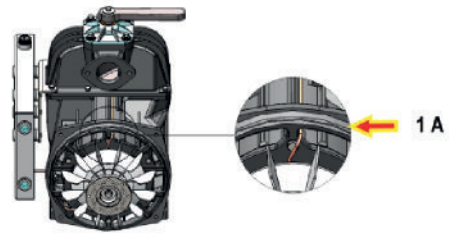

Fig. H.20 - Phase 0060 - part 2



Fig. H.21 - Phase 0060 - part 3

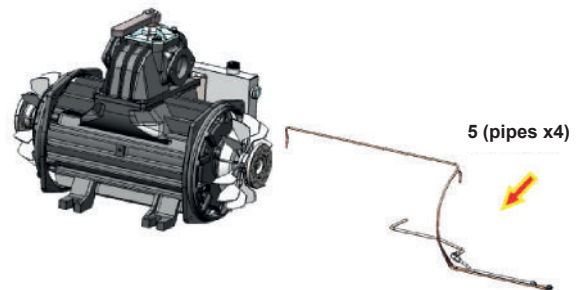

Fig. H.22 - Phase 0060 - part 4

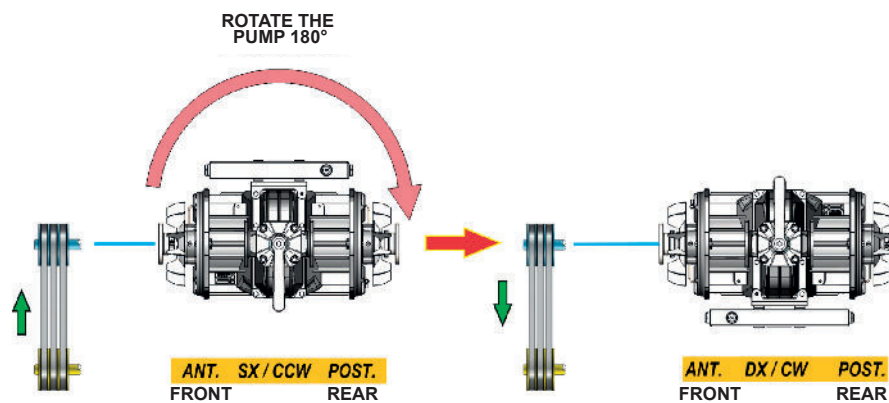

Fig. H.23 - Phase 0070

Phase 0080

- Now reassemble the vacuum pump, following all the steps in reverse order.
- Be careful when reassembling. Ensure that the coupling of the oil pump fits into the keyway of the drive flange.
- If necessary, fit the oil pump last to facilitate reassembly.



WARNING!

The oil pump (**pos. 4B Fig. H.17**) must be replaced from left to right or vice versa. See exploded views for part numbers.

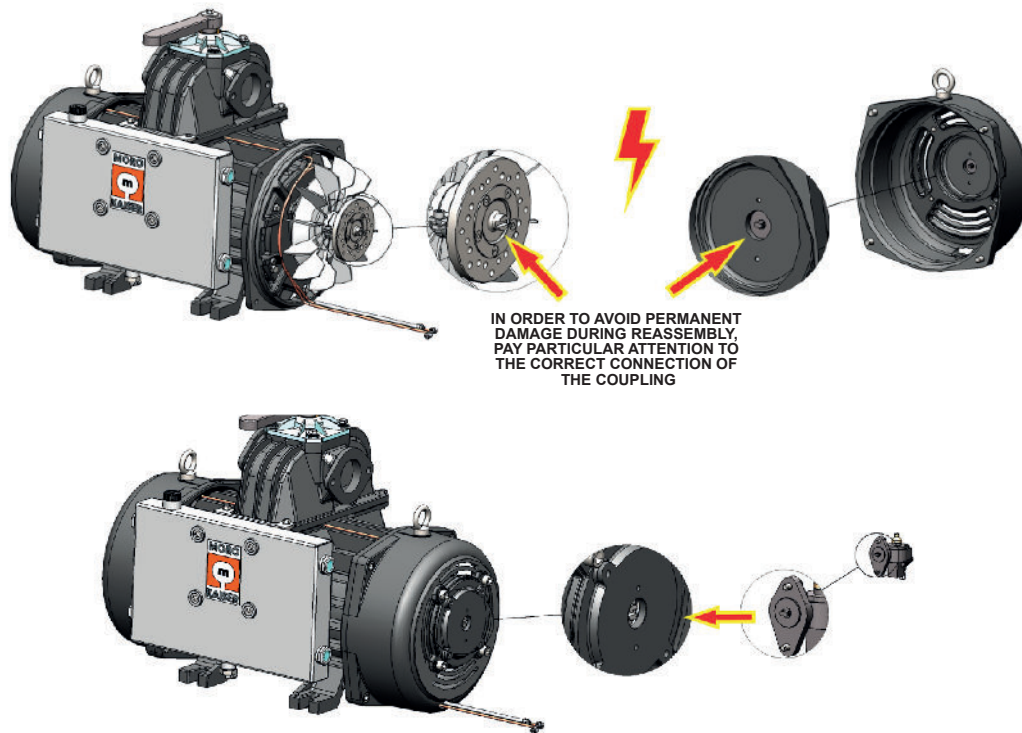

Fig. H.24 - Phase 0080

Maintenance, malfunctions, failures, troubleshooting.



J. Maintenance of the pump

J.1 Running in

The first 50 hours of actual operation of the pump are the running-in period. During this period, regularly check the consumption of disposable oil, the discharge temperature and the wear of the vanes. Vane wear should be minimum or negligible. If it is excessive, wear must be checked at regular frequent intervals and the phenomenon should be notified to an authorized dealer.

In any case, replace the vanes when wear is **5 mm** or more, see paragraph **J.4 Vane wear control procedure, page 44**.



WARNING!

It is forbidden to use the pump with vane wear more than the authorized **5 mm**. Failure to follow this warning relieves the manufacturer of all liability.

J.2 Periodic checks

Periodic checks and maintenance of the machinery are recommended:

- **SEVERL TIMES A DAY:**
 - check the maximum temperature at discharge.
- **DAILY:**
 - check the vacuum and the pressure during operation.
 - check the level of the disposable oil.
- **WEEKLY:**
 - clean the filtering elements of all the filters.
 - check the safety valve.
- **MONTHYL (OR EVERY 100 WORKING HOURS):**
 - check vane wear.
 - carry out internal cleaning of the pump by flushing with diesel oil, see procedure **J.3 Internal pump body flushing procedure, page 43.**



Sealing and sliding surfaces must be free from oil carbon deposits so that the function of the non-return valve is preserved; brief period of free suction is suggested before switching off the pumps.



WARNING!

The times indicated refer to normal working conditions. For harsh conditions, decrease the intervals for each operation.
Keep the pump clean in order to allow better cooling.

J.3 Internal pump body flushing procedure

1	Diesel oil
2	Input pipe
3	Free air flow
4	Discharge filter
5	Drainages

- Switch off the drive system and free the tank and the suction and discharge system from vacuum or pressure.
- Open the tank shutters. Set up the system so that free air can flow through the vacuum pump in the direction from the tank to the discharge.
- Fill a container with approx. **2 kg** of diesel fuel.

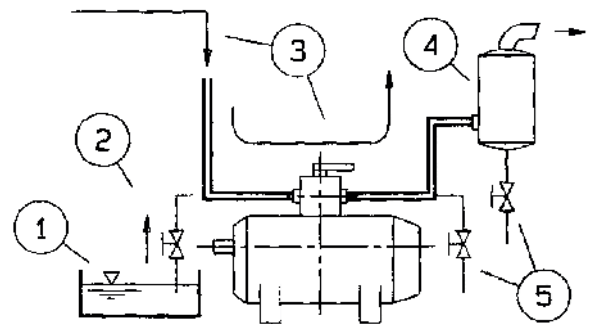

Fig. J.1 - Flushing

- Connect a rubber hose to the drainage tap upstream of the vacuum pump using a hose clip.
- Immerse the free end of the hose in the diesel container.
- Start the vacuum pump and check the suction of the diesel (**approx 3÷4 min**); if necessary, repeat the operation.
- Stop the vacuum pump.
- Remove the rubber hose; drain and clean the pipes and the exhaust filter.



Collect and dispose of diesel residues and any sludge appropriately.

- At the next restart, proceed with the initial start-up procedure and additional lubrication according to the instructions in paragraph **H. Start-up, put into operation, page 30**.

J.4 Vane wear control procedure

It is possible to check the wear of the rotor vanes without dismantling the pump:

- Remove hexagon socket cap **pos.1 Fig. H.4, page 33.**
- Insert a rod (diameter **6 mm** length **100 mm**) into the hole, **Fig. J.2.**
- Turn the rotor shaft by hand until the rod touches the outer diameter of the rotor, **Fig. J.2.**
- Mark the rod at the height of the threaded hole with a marking, **Fig. J.2.**
- Turn the rotor again until the rod enters a slot in the vanes, **Fig. J.3.**
- Mark the rod again with the point and measure the difference between the two measurements, **Fig. J.3.**
- The difference can be a maximum of **5 mm**. If the difference is greater, replace all the vanes immediately.

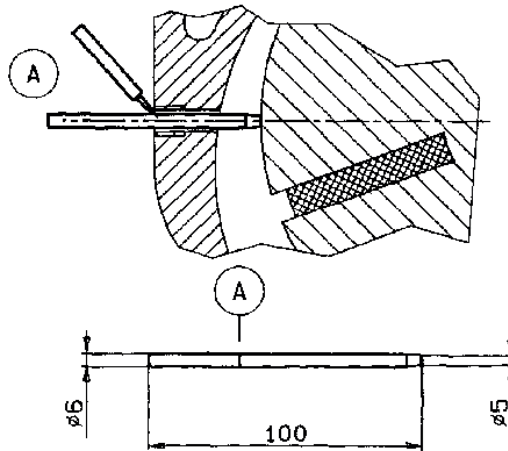

Fig. J.2 - Control - part 1

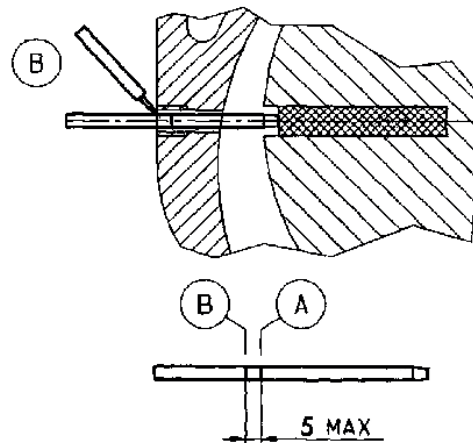

Fig. J.3 - Control - part 2



WARNING!

If it is necessary to replace the vanes, contact an authorised workshop.



WARNING!

Working with worn vanes can seriously damage the vacuum pump. Failure to observe this instruction releases the manufacturer **Moro Kaiser srl** from all liability.

- After measuring, re-screw the cap with sealing paste or Teflon.



WARNING!

Without the plug the flow rate and vacuum are reduced.



WARNING!

For maintenance and/or repair use only original **Moro Kaiser srl** spare parts, which offer the best characteristics of quality, reliability and safety. Failure to use original spare parts releases the manufacturer **Moro Kaiser srl** from any liability.

J.5 Troubleshooting

FAULT	CAUSES	REMEDIES
Reduced vacuum	Leakage or partial obstruction in the system components. The vanes are stuck in their seat. No lubrication.	Check the valves and elements in the system. Flush the vacuum pump with diesel fuel (see J.3 Internal pump body flushing procedure, page 43). Check the level of the disposable oil.
Inverse rotation of the vacuum pump, with vacuum in the tank	Non-return valve not hermetically sealed.	Contact an authorised service centre.
Excessive continuous knocking noise..	Excessive vane wear. No lubrication. The vanes are stuck in their seat. Rev speed too low.	Replace the vanes. Contact an authorised service centre. Check disposable oil level. Flush the vacuum pump with diesel fuel (see J.3 Internal pump body flushing procedure, page 43). Increase the number of revs up to 1200 rpm .
Overheating of the vacuum pump.	Operation conditions too harsh or continuous.	Let the pump cool down. Contact an authorised service centre.
The pump does not reach rated pressure, or gets stuck.	Suction of liquids, mud or foreign bodies.	Flush the vacuum pump with diesel fuel immediately (see J.3 Internal pump body flushing procedure, page 43).
Excessive consumption of disposable oil.	Use gaskets.	Contact an authorised service centre.



WARNING!

If the fault persists, apply to an authorized service centre.

K

Technical drawings and exploded views

K. Technical drawings and exploded views

K.1 References

For spare parts and technical service, please refer to the information in chapters “Assistance”, page 62 and “Contacts”, page 64.

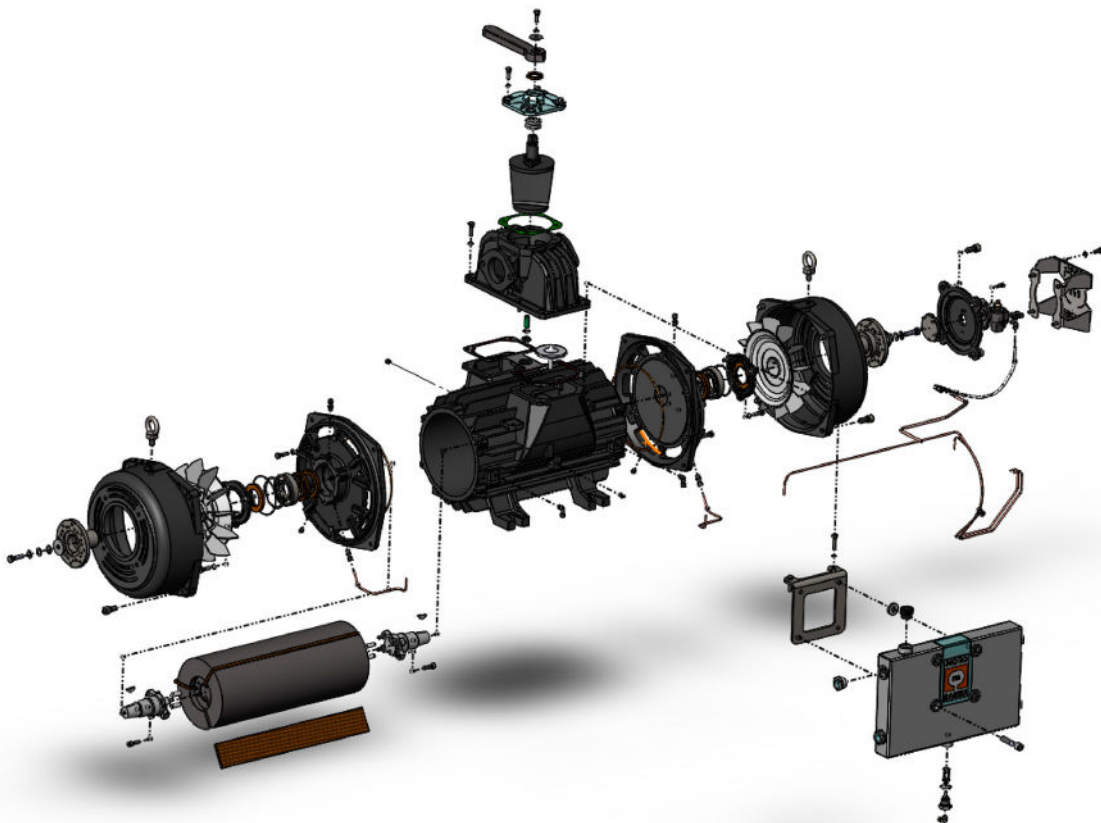

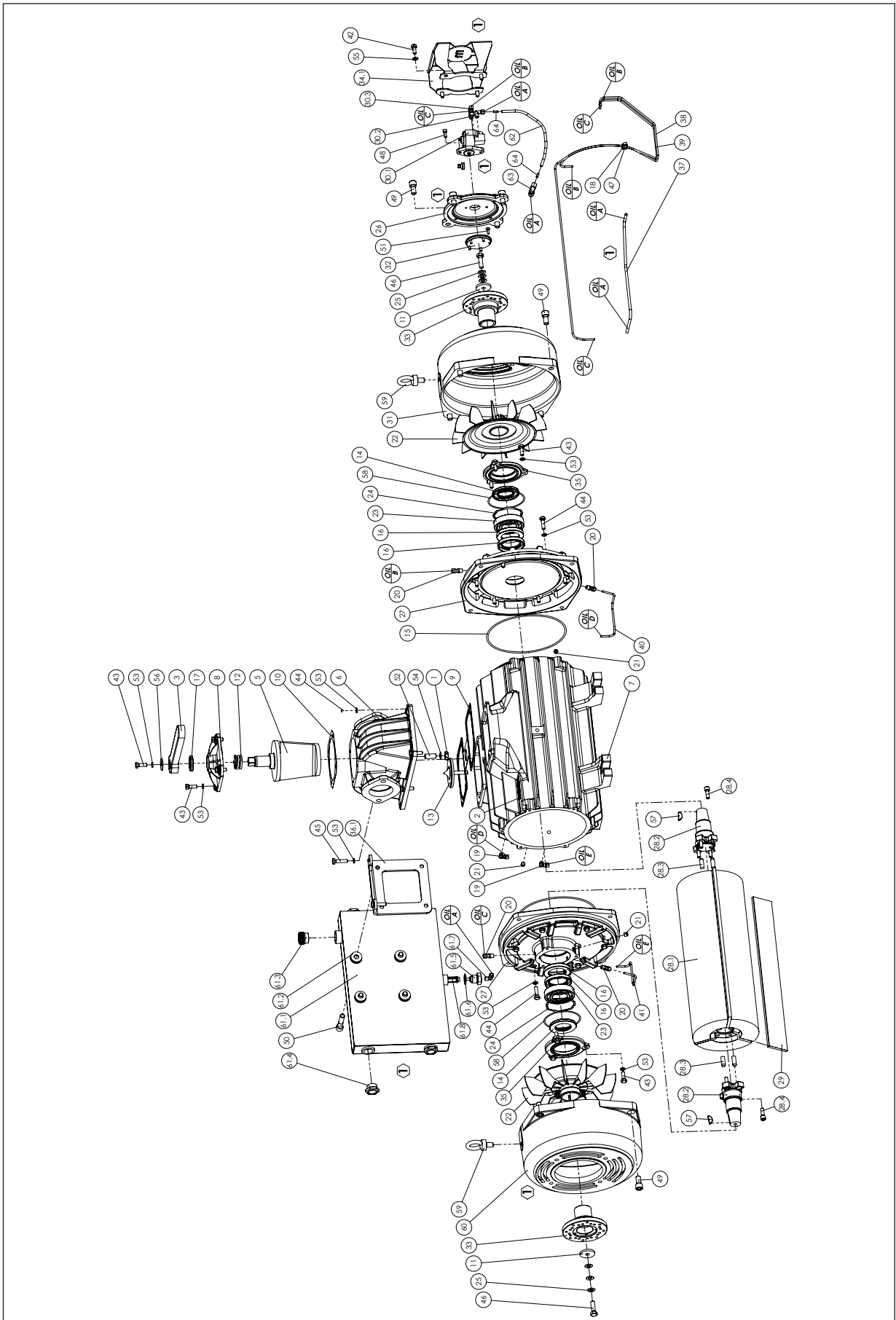

6.211005250-1/01

DECOMPRESSORE PM90T - SX
PM90T VACUUM PUMP - LEFT
POMPE À VIDE PM90T - GAUCHE
VAKUUMPUMPE PM90T - LINKS



Pos.	Q.tà M.ge Q.ty	Cod. n° Kod. n°	Denominazione	Denomination	Nomenclature	Bezeichnung
1	1	6.1013393-7-2	Dado	Nut	Ecrou	Mutter
2	1	6.1046708-7-2	Targhetta	Plate	Plaque	Plättchen
3	1	6.602400040-2	Leva deviatore	Lever	Levier	Hebel
4	1	6.607300580-2	Targhetta freccia	Plate	Plaque	Plättchen
5	1	6.626400280-2	Deviatore	Deviator	Déviateur	Umlenker
6	1	6.626400630-2	Collettore	Manifold	Collecteur	Umschaltkopf
7	1	6.662400510-2	Corpo	Housing	Corps	Häuse
8	1	6.663300970-2	Coperchio	Cover	Couvercle	Deckel
9	1	6.680502610-2	Guarnizione	Gasket	Joint	Dichtung
10	1	6.680600620-1	Guarnizione	Gasket	Joint	Dichtung
11	2	6.683000101-2	Rondella	Washer	Rondelle	Unterlegscheibe
12	1	6.690000342-2	Molla	Spring	Ressort	Feder
13	1	6.692500020-2	Valvola	Valve	Soupape	Ventil
14	2	6.921002004-2	Anello tenuta	Seal ring	Anneau d'étanchéité	Ring
15	2	6.921003522-2	Anello OR	O-ring	Anneau OR	OR-Ring
16	4	6.921027058-2	Anello tenuta	Seal ring	Anneau d'étanchéité	Ring
17	1	6.921027065-2	Anello tenuta	Seal ring	Anneau d'étanchéité	Ring
18	1	6.922000000-1	Fascetta	Clamp	Collier	Schlauchklemme
19	2	6.924061050-2	Raccordo	Hose fitting	Raccord	Reduzierung
20	4	6.924063050-2	Raccordo	Hose fitting	Raccord	Reduzierung
21	4	6.925070000-2	Tappo	Plug	Bouchon	Deckel
22	2	6.929080000-2	Ventola	Fan	Ventilateur	Lüfter
23	2	6.931004004-2	Cuscinetto	Bearing	Coussinet	Gleitlager
24	2	6.963005004-2	Anello	Ring	Anneau	Ring
25	6	6.964062002-2	Molla	Spring	Ressort	Feder
26	1	43105100008	Flangia	Flange	Flasque	Flansch
27	2	43105100011	Flangia	Flange	Flasque	Flansch
28	1	43303100002	Assieme rotore	Rotor group	Groupe rotor	Rotor
28.1	1	6.653400791-2	Rotore	Rotor	Rotor	Rotor-gruppe
28.2	2	6.611000750-1	Mozzo	Hub	Moyeu	Nabe
28.3	4	47370130032	Spina	Plug	Axe	Stift
28.4	8	47300310583	Vite	Screw	Vis	Schraube
29	3	43305500026	Lamella	Vane	Palette	Lamellen
30	1	43503200008	Kit pompa olio	Oil pump kit	Kit pompe d'huile	Ölpumpe-Kit
30.1	1	6.927040007-1	Pompa olio sx	Left oil pump	Pompe d'huile gauche	Ölpumpe links
30.2	1	6.924019025-2	Raccordo	Hose fitting	Raccord	Reduzierung
30.3	2	6.924063050-2	Raccordo	Hose fitting	Raccord	Reduzierung
31	1	43504100013	Copriventola	Housing	Carter	Gehäuse
32	1	43505100139	Flangia	Flange	Flasque	Flansch
33	2	43505100141	Mozzo	Hub	Moyeu	Nabe

Pos.	Q.tà M.ge Q.ty	Cod. n° Kod. n°	Denominazione	Denomination	Nomenclature	Bezeichnung
34	1	43505100162	Carter	Housing	Carter	Gehäuse
34.1	-					
35	2	43505100145	Flangia	Flange	Flasque	Flansch
36	1	43505100146	Supporto	Support	Support	Halterung
36.1	-					
37	1	43505100154	Tubo olio aspirazione	Hose	Tuyau	Rohr
38	1	43505100155	Tubo olio mandata	Hose	Tuyau	Rohr
39	1	43505100156	Tubo olio mandata	Hose	Tuyau	Rohr
40	1	43505100157	Tubo olio mandata	Hose	Tuyau	Rohr
41	1	43505100158	Tubo olio mandata	Hose	Tuyau	Rohr
42	4	47300250078	Vite	Screw	Vis	Schraube
43	11	47300250083	Vite	Screw	Vis	Schraube
44	16	47300250087	Vite	Screw	Vis	Schraube
45	2	47300250090	Vite	Screw	Vis	Schraube
46	2	47300250133	Vite	Screw	Vis	Schraube
47	1	47300310105	Vite	Screw	Vis	Schraube
48	2	47300310116	Vite	Screw	Vis	Schraube
49	12	47300310308	Vite	Screw	Vis	Schraube
50	4	47300310337	Vite	Screw	Vis	Schraube
51	5	47300340024	Vite	Screw	Vis	Schraube
52	1	47310040072	Grano	Dowel	Goujon	Haltestein
53	29	47350130011	Rondella	Washer	Rondelle	Unterlegscheibe
54	1	47350160028	Rondella	Washer	Rondelle	Unterlegscheibe
55	4	47350190039	Rondella	Washer	Rondelle	Unterlegscheibe
56	1	47350250025	Rondella	Washer	Rondelle	Unterlegscheibe
57	2	47410040003	Linguetta	Key	Clavette	Lasche
58	2	47450000045	Anello OR	O-ring	Anneau OR	OR-Ring
59	2	47530070004	Golfaro	Eye bolt	Cheville à oeillet	Ringschraube
60	1	43504100016	Copriventola	Housing	Carter	Gehäuse
61	1	43503100008	Gruppo serbatoio olio	Oil reservoir group	Groupe reservoir huile	Hydrauliköl-gruppe
61.1	1	43504100017	Serbatoio olio	Oil reservoir	Reservoir huile	Hydrauliköl
61.2	4	43505100160	Rondella	Washer	Rondelle	Unterlegscheibe
61.3	1	6.927096056-2	Tappo carico olio	Plug	Bouchon	Deckel
61.4	4	6.965022002-2	Tappo spia livello	Plug	Bouchon	Deckel
61.5	1	6.673003830-1	Raccordo	Hose fitting	Raccord	Reduzierung
61.6	1	6.964014007-2	Rosetta	Washer	Rondelle	Unterlegscheibe
61.7	1	6.924019025-2	Raccordo	Hose fitting	Raccord	Reduzierung
61.8	1	6.644500000-2	Filtro	Filter	Filtre	Filter
61.9	1	49115000116	Adesivo	Plate	Plaque	Schutzblech
62	1	43505100161	Tubo olio aspirazione	Hose	Tuyau	Rohr

6.211005250-1/01

DECOMPRESSORE PM90T - SX
 PM90T VACUUM PUMP - LEFT
 POMPE À VIDE PM90T - GAUCHE
 VAKUUMPUMPE PM90T - LINKS



Pos.	Q.tà M.ge Q.ty	Cod. n° Kod. n°	Denominazione	Denomination	Nomenclature	Bezeichnung
63	1	6.924023100-2	Raccordo	Hose fitting	Raccord	Reduzierung
64	2	6.1016817-8-2	Ogiva	Ogive	Ogive	Ogiven
65	-	6.1008649-9-2	Kit guarnizioni	Gasket kit	Kit joint	Dichtung-Kit
66						
67						
68						
69						
70						
71						
72						
73						
74						
75						
76						
77						
78						
79						
80						
81						
82						
83						
84						
85						
86						
87						
88						
89						
90						
91						
92						
93						
94						
95						
96						
97						
98						
99						
100						
101						

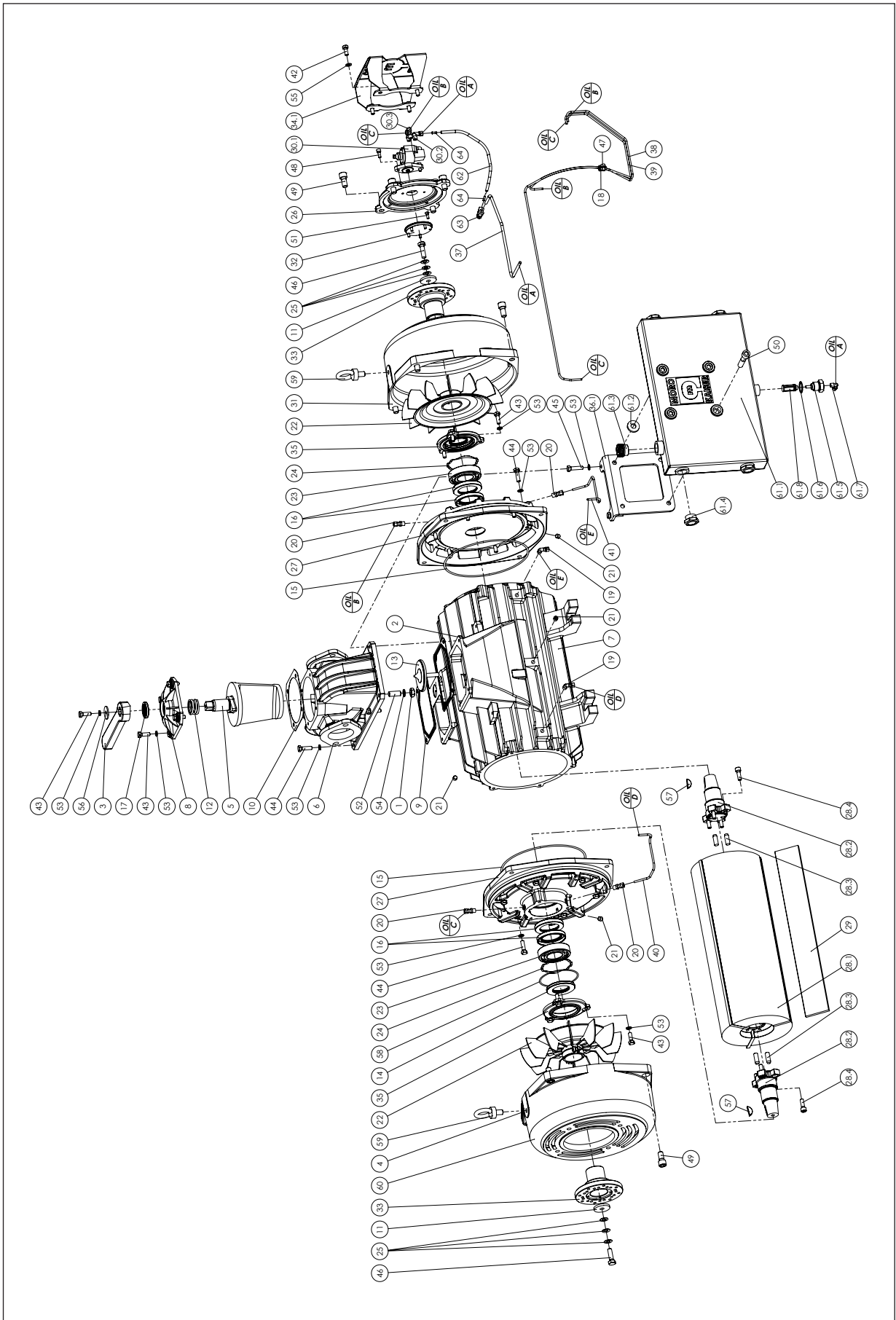

6.211005260-1/00

DECOMPRESSORE PM90T - DX
PM90T VACUUM PUMP - RIGHT
POMPE À VIDE PM90T - DROIT
VAKUUMPUMPE PM90T - RECHTS



Pos.	Q.tà M.ge Q.ty	Cod. n° Kod. n°	Denominazione	Denomination	Nomenclature	Bezeichnung
1	1	6.1013393-7-2	Dado	Nut	Ecrou	Mutter
2	1	6.1046708-7-2	Targhetta	Plate	Plaque	Plättchen
3	1	6.602400040-2	Leva deviatore	Lever	Levier	Hebel
4	1	6.607300580-2	Targhetta freccia	Plate	Plaque	Plättchen
5	1	6.626400280-2	Deviatore	Deviator	Déviateur	Umlenker
6	1	6.626400630-2	Collettore	Manifold	Collecteur	Umschaltkopf
7	1	6.662400510-2	Corpo	Housing	Corps	Häuse
8	1	6.663300970-2	Coperchio	Cover	Couvercle	Deckel
9	1	6.680502610-2	Guarnizione	Gasket	Joint	Dichtung
10	1	6.680600620-1	Guarnizione	Gasket	Joint	Dichtung
11	2	6.683000101-2	Rondella	Washer	Rondelle	Unterlegscheibe
12	1	6.690000342-2	Molla	Spring	Ressort	Feder
13	1	6.692500020-2	Valvola	Valve	Soupape	Ventil
14	2	6.921002004-2	Anello tenuta	Seal ring	Anneau d'étanchéité	Ring
15	2	6.921003522-2	Anello OR	O-ring	Anneau OR	OR-Ring
16	4	6.921027058-2	Anello tenuta	Seal ring	Anneau d'étanchéité	Ring
17	1	6.921027065-2	Anello tenuta	Seal ring	Anneau d'étanchéité	Ring
18	1	6.922000000-1	Fascetta	Clamp	Collier	Schlauchklemme
19	2	6.924061050-2	Raccordo	Hose fitting	Raccord	Reduzierung
20	4	6.924063050-2	Raccordo	Hose fitting	Raccord	Reduzierung
21	4	6.925070000-2	Tappo	Plug	Bouchon	Deckel
22	2	6.929080000-2	Ventola	Fan	Ventilateur	Lüfter
23	2	6.931004004-2	Cuscinetto	Bearing	Coussinet	Gleitlager
24	2	6.963005004-2	Anello	Ring	Anneau	Ring
25	6	6.964062002-2	Molla	Spring	Ressort	Feder
26	1	43105100008	Flangia	Flange	Flasque	Flansch
27	2	43105100011	Flangia	Flange	Flasque	Flansch
28	1	43303100002	Assieme rotore	Rotor group	Groupe rotor	Rotor
28.1	1	6.653400791-2	Rotore	Rotor	Rotor	Rotor-gruppe
28.2	2	6.611000750-1	Mozzo	Hub	Moyeu	Nabe
28.3	4	47370130032	Spina	Plug	Axe	Stift
28.4	8	47300310583	Vite	Screw	Vis	Schraube
29	3	43305500026	Lamella	Vane	Palette	Lamellen
30	1	43503200009	Kit pompa olio	Oil pump kit	Kit pompe d'huile	Ölpumpe-Kit
30.1	1	6.927040006-1	Pompa olio dx	Right oil pump	Pompe d'huile droit	Ölpumpe rechts
30.2	1	6.924019025-2	Raccordo	Hose fitting	Raccord	Reduzierung
30.3	2	6.924063050-2	Raccordo	Hose fitting	Raccord	Reduzierung
31	1	43504100013	Copriventola	Housing	Carter	Gehäuse
32	1	43505100139	Flangia	Flange	Flasque	Flansch
33	2	43505100141	Mozzo	Hub	Moyeu	Nabe

Pos.	Q.tà M.ge Q.ty	Cod. n° Kod. n°	Denominazione	Denomination	Nomenclature	Bezeichnung
34	1	43505100162	Carter	Housing	Carter	Gehäuse
34.1	-					
35	2	43505100145	Flangia	Flange	Flasque	Flansch
36	1	43505100146	Supporto	Support	Support	Halterung
36.1	-					
37	1	43505100154	Tubo olio aspirazione	Hose	Tuyau	Rohr
38	1	43505100155	Tubo olio mandata	Hose	Tuyau	Rohr
39	1	43505100156	Tubo olio mandata	Hose	Tuyau	Rohr
40	1	43505100157	Tubo olio mandata	Hose	Tuyau	Rohr
41	1	43505100158	Tubo olio mandata	Hose	Tuyau	Rohr
42	4	47300250078	Vite	Screw	Vis	Schraube
43	11	47300250083	Vite	Screw	Vis	Schraube
44	16	47300250087	Vite	Screw	Vis	Schraube
45	2	47300250090	Vite	Screw	Vis	Schraube
46	2	47300250133	Vite	Screw	Vis	Schraube
47	1	47300310105	Vite	Screw	Vis	Schraube
48	2	47300310116	Vite	Screw	Vis	Schraube
49	12	47300310308	Vite	Screw	Vis	Schraube
50	4	47300310337	Vite	Screw	Vis	Schraube
51	5	47300340024	Vite	Screw	Vis	Schraube
52	1	47310040072	Grano	Dowel	Goujon	Haltestein
53	29	47350130011	Rondella	Washer	Rondelle	Unterlegscheibe
54	1	47350160028	Rondella	Washer	Rondelle	Unterlegscheibe
55	4	47350190039	Rondella	Washer	Rondelle	Unterlegscheibe
56	1	47350250025	Rondella	Washer	Rondelle	Unterlegscheibe
57	2	47410040003	Linguetta	Key	Clavette	Lasche
58	2	47450000045	Anello OR	O-ring	Anneau OR	OR-Ring
59	2	47530070004	Golfaro	Eye bolt	Cheville à oeillet	Ringschraube
60	1	43504100016	Copriventola	Housing	Carter	Gehäuse
61	1	43503100008	Gruppo serbatoio olio	Oil reservoir group	Groupe reservoir huile	Hydrauliköl-gruppe
61.1	1	43504100017	Serbatoio olio	Oil reservoir	Reservoir huile	Hydrauliköl
61.2	4	43505100160	Rondella	Washer	Rondelle	Unterlegscheibe
61.3	1	6.927096056-2	Tappo carico olio	Plug	Bouchon	Deckel
61.4	4	6.965022002-2	Tappo spia livello	Plug	Bouchon	Deckel
61.5	1	6.673003830-1	Raccordo	Hose fitting	Raccord	Reduzierung
61.6	1	6.964014007-2	Rosetta	Washer	Rondelle	Unterlegscheibe
61.7	1	6.924019025-2	Raccordo	Hose fitting	Raccord	Reduzierung
61.8	1	6.644500000-2	Filtro	Filter	Filtre	Filter
61.9	1	49115000116	Adesivo	Plate	Plaque	Schutzblech
62	1	43505100161	Tubo olio aspirazione	Hose	Tuyau	Rohr

6.211005260-1/00

DECOMPRESSORE PM90T - DX
 PM90T VACUUM PUMP - RIGHT
 POMPE À VIDE PM90T - DROIT
 VAKUUMPUMPE PM90T - RECHTS



Pos.	Q.tà M.ge Q.ty	Cod. n° Kod. n°	Denominazione	Denomination	Nomenclature	Bezeichnung
63	1	6.924023100-2	Raccordo	Hose fitting	Raccord	Reduzierung
64	2	6.1016817-8-2	Ogiva	Ogive	Ogive	Ogiven
65	-	6.1008649-9-2	Kit guarnizioni	Gasket kit	Kit joint	Dichtung-Kit
66						
67						
68						
69						
70						
71						
72						
73						
74						
75						
76						
77						
78						
79						
80						
81						
82						
83						
84						
85						
86						
87						
88						
89						
90						
91						
92						
93						
94						
95						
96						
97						
98						
99						
100						
101						

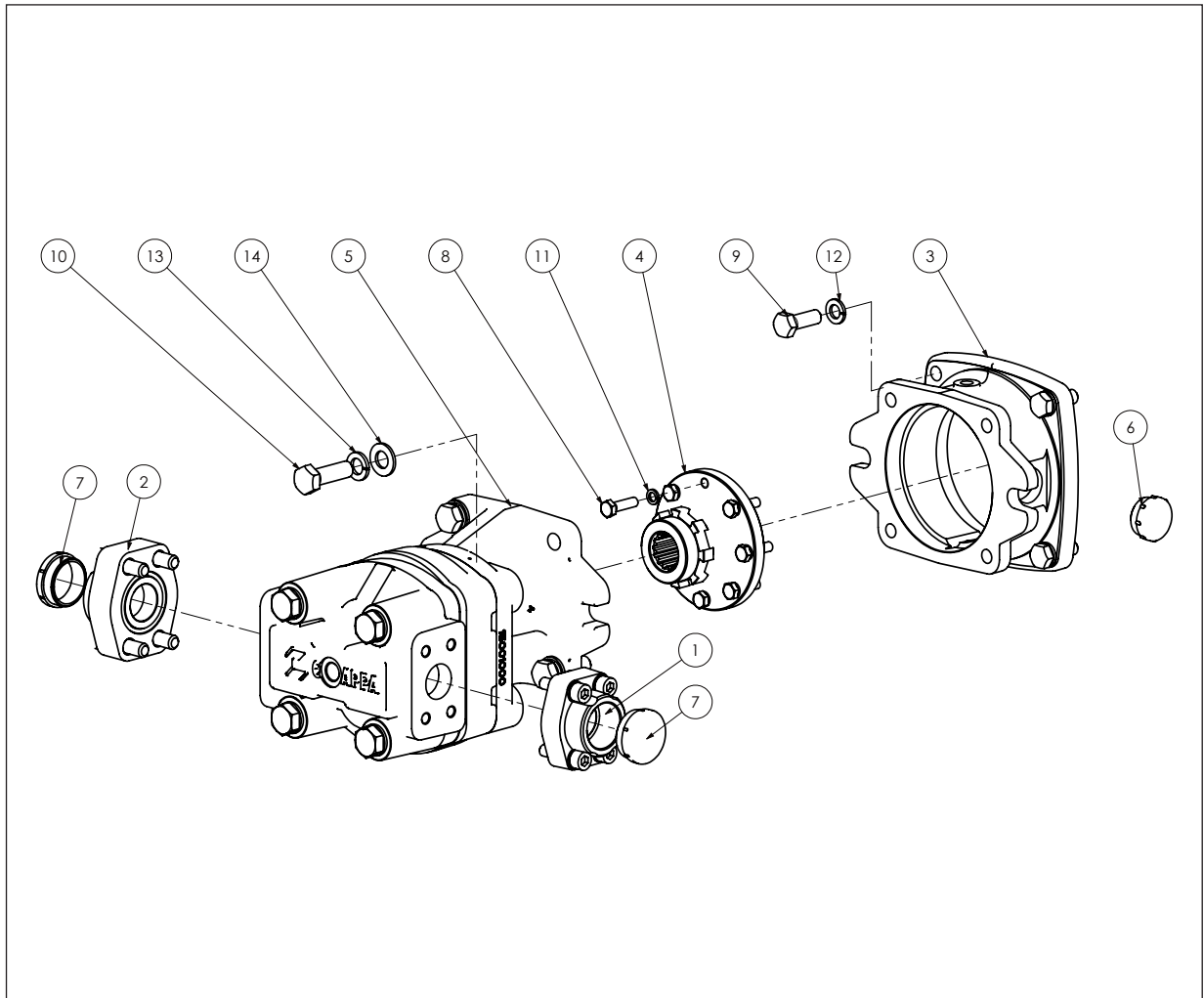

Pos.	Q.tà M.ge Q.ty	Cod. n° Kod. n°	Denominazione	Denomination	Nomenclature	Bezeichnung
1	1	6.924070003-2	Flangia	Flange	Flasque	Flansch
2	1	6.924070008-2	Flangia	Flange	Flasque	Flansch
3	1	43505100021	Distanziale	Spacer	Entretoise	Distanzring
4	1	43505100023	Flangia	Flange	Flasque	Flansch
5	1	44116000033	Motore idraulico	Hydraulic motor	Moteur hydraulique	Hydraulikmotor
6	1	44375000009	Tappo	Plug	Bouchon	Deckel
7	2	44375000010	Tappo	Plug	Bouchon	Deckel
8	8	47300250087	Vite	Screw	Vis	Schraube
9	4	47300250175	Vite	Screw	Vis	Schraube
10	4	47300250224	Vite	Screw	Vis	Schraube
11	8	47350130011	Rondella	Washer	Rondelle	Unterlegscheibe
12	4	47350130019	Rondella	Washer	Rondelle	Unterlegscheibe
13	4	47350130023	Rondella	Washer	Rondelle	Unterlegscheibe
14	4	47350190048	Rondella	Washer	Rondelle	Unterlegscheibe
15						
16						

43502100010/01

KIT COMANDO PNEUMATICO PM90T-PM150T
 PM90T-PM150T PNEUMATIC CONTROL KIT
 CONTRÔLE PNEUMATIQUE PM90T-PM150T
 PM90T-PM150T PNEUMATISCHE STEUERUNG

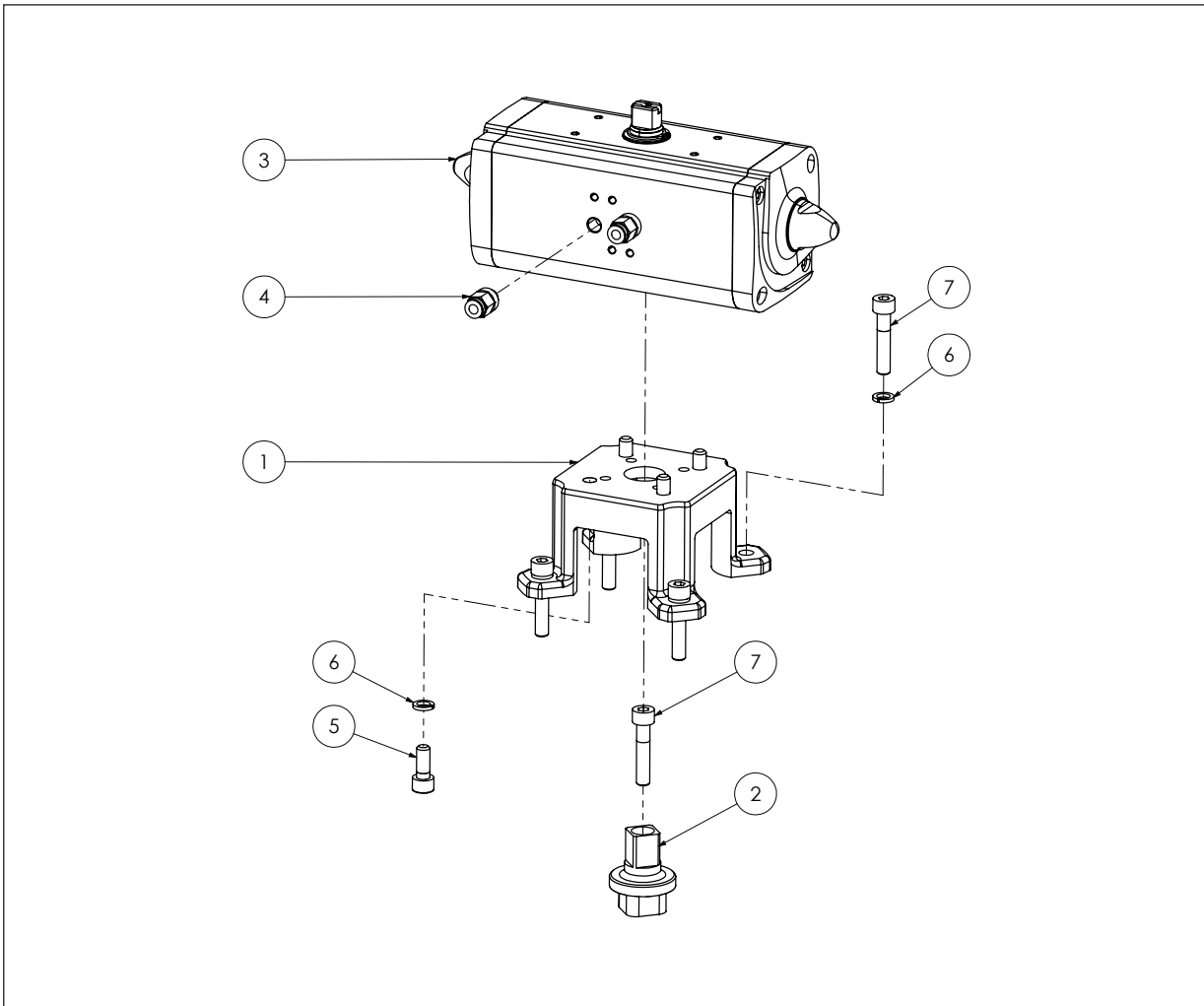

Pos.	Q.tà M.ge Q.ty	Cod. n° Kod. n°	Denominazione	Denomination	Nomenclature	Bezeichnung
1	1	43505100148	Supporto	Support	Support	Halterung
2	1	43504100015	Perno	Bolt	Axe	Stift
3	1	45816000040	Attuatore	Actuator	Actionneur	Aktuator
4	2	6.924063106-2	Raccordo	Fitting	Raccord	Verbindung
5	4	47300310186	Vite	Screw	Vis	Schraube
6	8	47350130011	Rondella	Washer	Rondelle	Unterlegscheibe
7	5	47300310201	Vite	Screw	Vis	Schraube
8						
9						
10						
11						
12						
13						
14						
15						
16						

Norms, national and international regulations.



N. Directives, Norms and evaluations

N.1 Directives and Norms

N.1.1 Directives

The following provisions were observed:

- Directive **2006/42/EC** of May 17th 2006 (also known as **The New Machinery Directive**) transposed and implemented in Italy through the Legislative Decree of January 37th 2010, n. 17 (published on February 2nd 2010 Ordinary Supplement n.36/L on the OFFICIAL JOURNAL, general Series - n.41). It replaces the Directive 98/37/EC of the European Parliament published on the Official Journal L 331 on December 17th 1998, which referred to all types of machinery and their safety components put singularly on the market (it modified Directive 89/392/EEC of June 14th 1998). This Directive came into forces across all Europe on December 29th 2009.



WARNING: To avoid danger and damage it is absolutely essential to follow the instructions given in this manual and any other instructions for use and maintenance attached to it. Further explanations and details on the information in this manual can be obtained from MORO KAISER S.R.L. "Service Centers".

N.1.2 Safety regulations

STANDARD	STANDARD TITLE
UNI EN ISO 12100-2:2009	Machinery safety. Fundamental concepts, general design principles.
UNI EN 1012-1:2010	Compressors and vacuum pumps - Safety requirements - Part 1: Air compressors.
UNI EN 1012-2:2009	Compressors and vacuum pumps - Safety requirements - Part 1: Vacuum pumps.

N.2 CE Certificate of conformity

 MORO KAISER COMPONENTS	MORO KAISER S.R.L. Via Pontebbana, 16, 33080 Fiume Veneto - PN (I)
DICHIARAZIONE DI CONFORMITA' CE	
La sottoscritta MORO KAISER SRL con sede legale in via Pontebbana n°16 - 33080 Fiume Veneto (PN)	
DICHIARA SOTTO LA PROPRIA RESPONSABILITA' CHE L'ALLESTIMENTO NUOVO DI FABBRICA:	
<i>Modello</i> <i>Tipo</i> <i>Matricola</i> <i>Anno di costruzione</i>	DECOMPRESSORE A PALLETTA PM90T XXXX AAAA
Quasi macchina progettata per l'aspirazione e la compressione di aria filtrata.	
DESCRITTO IN APPRESSO: E' CONFORME ALLE DISPOSIZIONI LEGISLATIVE CHE TRASPOSONO LA DIRETTIVA 2006/42/CE E SEGUENTI MODIFICHE	
Le norme applicate sono le seguenti: UNIEN 1012-1, UNIEN 1012-2, UNIEN 12100 [1-2]	
E' vietata la messa in esercizio di questa quasi macchina prima che l'impianto o l'attrezzatura in cui sarà incorporata siano stati dichiarati conformi alla Direttiva 2006/42 CE.	
Nome Posizione Dichiarazione n° DATA	Giuseppe ZILLE Responsabile Tecnico XXXX-XX GG/MM/AAAA
MORO KAISER SRL	
Ai sensi della direttiva 2006/42/CE la persona autorizzata a costituire il fascicolo tecnico è: Giuseppe ZILLE	
MORO KAISER S.R.L. Società a socio unico Via Pontebbana, 16 33080 Fiume Veneto (PN) Italy T +39 0434 951 211 F +39 0434 957 786 infomoro@morokaiser.it	
www.morokaiser.it Cap. Soc. € 100.000 i.v. Registro Imprese PN, Codice Fiscale e Partita Iva n. 11137450018, R.E.A. n. PN - 102479, PEC: morokaiser@legalmail.it	

 MORO KAISER COMPONENTS	MORO KAISER S.R.L. Via Pontebbana, 16, 33080 Fiume Veneto - PN (I)
CE CERTIFICATE OF CONFORMITY	
The undersigned MORO KAISER SRL - via Pontebbana n°16 - 33080 Fiume Veneto (PN)	
DECLARES UNDER ITS RESPONSIBILITY THAT THE PRODUCT:	
<i>Model</i> <i>Type</i> <i>Serial number</i> <i>Manufacturing year</i>	VANE VACUUM PUMP PM90T XXXX AAAA
Partly completed machine designed for the intake and compression of filtered air.	
IS IN COMPLIANCE WITH THE 2006/42/CE DIRECTIVE AND SUBSEQUENT MODIFICATIONS.	
The following regulations have been applied: UNIEN 1012-1, UNIEN 1012-2, UNIEN 12100 [1-2]	
This partly completed machine cannot be put in operation before the plant or the equipment it will be incorporated to, has been declared in compliance with the Directive 2006/42/CE.	
Name Position Certificate n° DATA	Giuseppe ZILLE Technical responsible XXXX-XX GG/MM/AAAA
MORO KAISER SRL	
Under Directive 2006/42/CE, the person authorized to compile the technical file is: Giuseppe ZILLE	
MORO KAISER S.R.L. Società a socio unico Via Pontebbana, 16 33080 Fiume Veneto (PN) Italy T +39 0434 951 211 F +39 0434 957 786 infomoro@morokaiser.it	
www.morokaiser.it Cap. Soc. € 100.000 i.v. Registro Imprese PN, Codice Fiscale e Partita Iva n. 11137450018, R.E.A. n. PN - 102479, PEC: morokaiser@legalmail.it	

Disassembly, scrapping and disposal of the equipment.

P

P. Disassembly, scrapping and disposal of the equipment

P.1 Separate and dispose the different types of material

To withdraw the equipment from service it is necessary to take steps to separate and dispose of the different types of material:

- hydraulic and lubrication oil
- plastic and rubber parts
- cooling liquid, disinfecting liquids and deodorants
- residues of materials collected in the tank
- parts in steel, aluminium and cast iron
- each of these should be disposed of according to the law.



Do not release polluting liquids into the environment
.Use specialist companies for the disposal of all materials, for the treatment and recycling of all oils and material, and for material resulting from the final scrapping of the machine.



ATTENZIONE!

Do not use disassembled parts to be scrapped as spare parts. Failure to comply with the above provisions releases the manufacturer **Moro Kaiser srl** from all liability and represents negligent use of the product.

Q

Ecology, environment and disposal.

Q. Ecology and the environment

Q.1 Storage and disposal

For the storage and disposal of polluting material and substances, always remember to respect local laws.

If local laws do not cover the treatment, storage or disposal, products which are dangerous or damaging to the environment should be dealt with and handled with commonsense.

The following are some brief indications of a general character which should be of help.

Q.1.1 Specific symbols

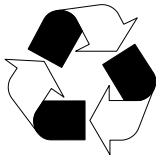

This symbol precedes indications concerning the environment in general and the ways of working in safety and for its protection.



This symbol precedes indications concerning the environment in general and the disposal or recycling of those elements dangerous for the environment.



This symbol precedes indications concerning the prohibition of disposing waste into drains, rivers, the land and the environment in general.

Q.2 Warnings



- Do not simply throw into the environment (rivers, land, sewer systems) such products as lubricants, liquids from cooling systems, flammable materials, acids, hydraulic oils or indeed any type of polluting substance.

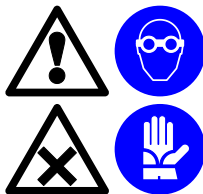

- These substances are dangerous and usually damaging to the health. Prevent contact with the eyes or skin. When handling polluting or poisonous substances, protect the eyes and hands and wear appropriate clothing.
- Do not refill the tanks from pressurised tanks or refill equipment as these can cause liquids to leak or escape into the environment.
- Do not burn lubricating or hydraulic oils in heating systems or in the open. Store such materials carefully until they can be disposed of in accordance with the law.
- Do not mix different liquids. Store until they can be disposed of in accordance with the law.



- Immediately repair any leakage or defect in the motor, the hydraulic system or the cooling system. Defective equipment can be dangerous to the operator, the public and/or the environment.



- Do not increase the pressure within pressurised systems as this could lead to an explosion of components or tubes and the release of dangerous substances into the environment.
- Do not carry out welding or soldering operations as this might damage flexible tubes making them dangerous both to the operator and the public, and to the environment.
- Extra-ordinary maintenance work should only be carried out in workshops recommended by the constructor.



- All material resulting from ordinary or extra-ordinary maintenance must be disposed of in accordance with the law.



- At the end of its working life, when the equipment or any individual component is to be scrapped, it should be dealt with in accordance with the instructions given in section O of this manual.

R

Assistance, maintenance and services.

R. Assistance

R.1 Assistance, maintenance and services

The technical assistance is carried out by the Dealers, the Authorized Workshops, the Manufacturer or directly by MORO KAISER S.R.L..

MORO KAISER S.R.L.
VIA PONTEBBANA 16
33080 FIUME VENETO (PN) ITALY
Tel. +39 (0)434 951211
Fax +39 (0)434 957786

R.2 Warranty regulations

R.2.1 Duration

Moro Kaiser srl (the Manufacturer), in presence of defects for which is established the liability of the manufacturer, warranties the product up to 1 year (12 months) from date of purchase by the bodybuilder of the vehicle or, in case of sale of parts, to the end user. The initial date of the warranty must be clearly shown on a valid document, such as DDT or Invoice issued to the bodybuilder of the vehicle or to the end user, either from Manufacturers or its Official Dealer. These documents must contain the exact description, part number and, where present, the serial number of the product.

The Manufacturer recognizes additional 6 months of storage for the goods before the warranty start only for Official Dealers and only if the product is purchased and storage. The storage must give adequately protection against any action which would affect or impair the aesthetic appearance as well as its technical operation. The duration of storage before the warranty period must always be proven by the Official Dealer with valid documents to the tax effects, such as DDT or Invoice issued to the bodybuilder

of the superstructure or to the end user, containing a description of the product, part number and serial number. In any case, the expiry of the Warranty shall not exceed 18 (eighteen) months from date of shipment by **Moro Kaiser srl**.

R.2.2 Validity

Warranty includes free repair or replacement of parts of product and in the cases decided solely by the Manufacturer the replacement of the complete product.

R.2.3 Limitations and Liability

The Warranty is applied only to the product excluding any additional costs as: transportation cost and replacement cost made by our staff (Manufacturer). Warranties are not recognized on breakdown due to the failure of the Product subject to usury and consumables.

The manufacturer does not recognize Warranties for any tampering or changes in the Product, except with the prior written permission. They are excluded from the warranty repairs performed by persons other than those specific technical knowledge or by people outside our network.

Are excluded from warranty coverage also the damage due to improper or wrong installation- that does not conform to the installation instructions or in the absence of these non-performed in a workmanlike manner, incorrect or inadequate maintenance as specified in the relevant instructions' use or otherwise according to the usual maintenance, operation or misuse, mistreatment, neglect or failure to use however for all kinds of causes beyond the control **Moro Kaiser srl**.

The manufacturer disclaims any liability for any damage that may directly or indirectly to persons, things or animals resulting from the failure to observe all safety rules and instructions given by the User and Instructions manual of the Product .

The warranty is voided if they are not respected in the warranty period the scheduled maintenance or the required checks by the Manufacturer in the User and Instructions manual of the Product .

R.2.4 Settlement of Disputes

Any dispute arising out of execution of the guarantee will be referred to the Court of **Pordenone - Italy**.



Contacts.

S. Contacts

S.1 Information to get in contact with us

MORO KAISER S.R.L.
Via Pontebbana, 16
33080 FIUME VENETO (PN) ITALY
Tel. +39 (0)434 951211
Fax: +39 (0)434 957786
infomoro@morokaiser.it

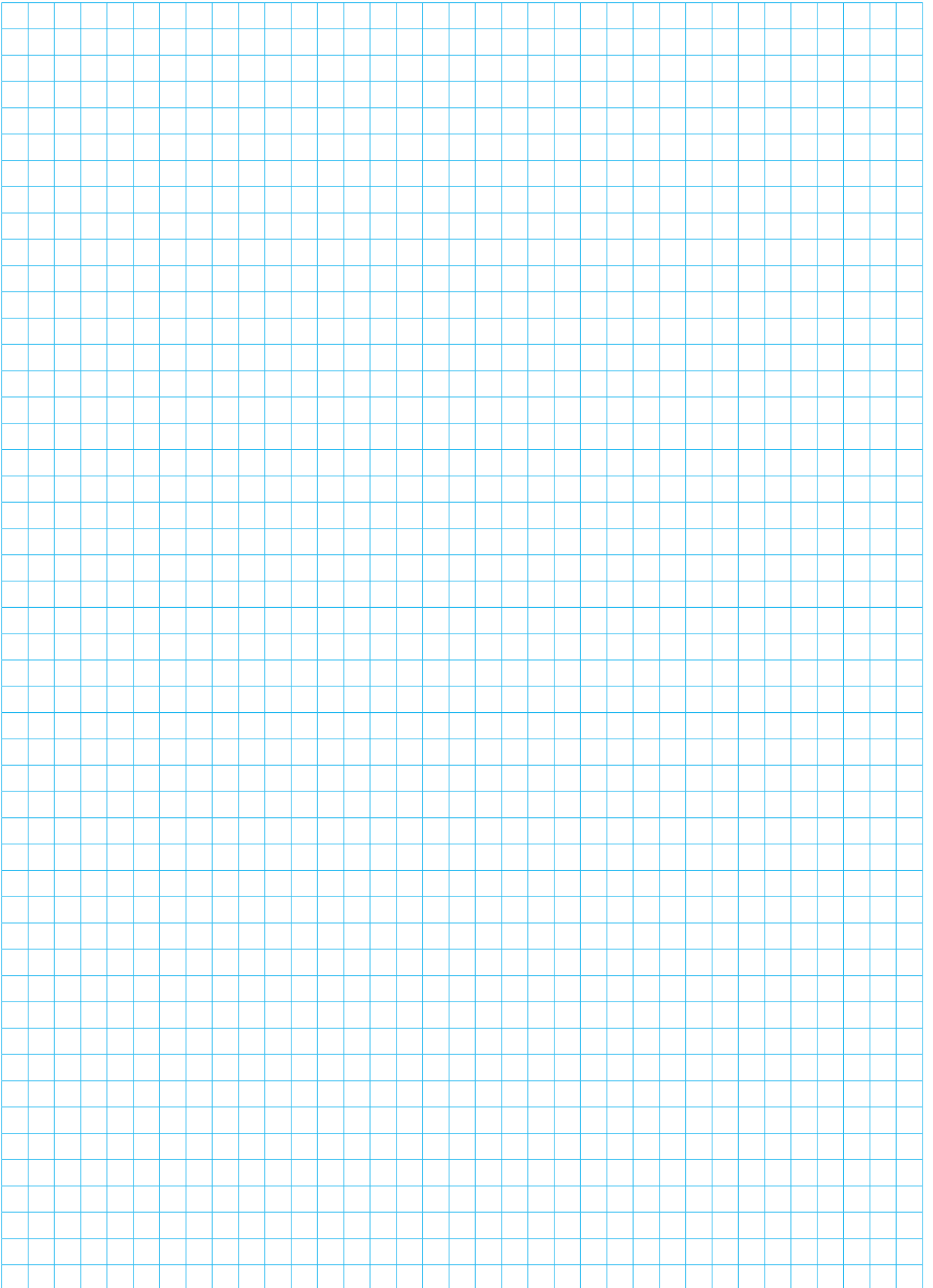

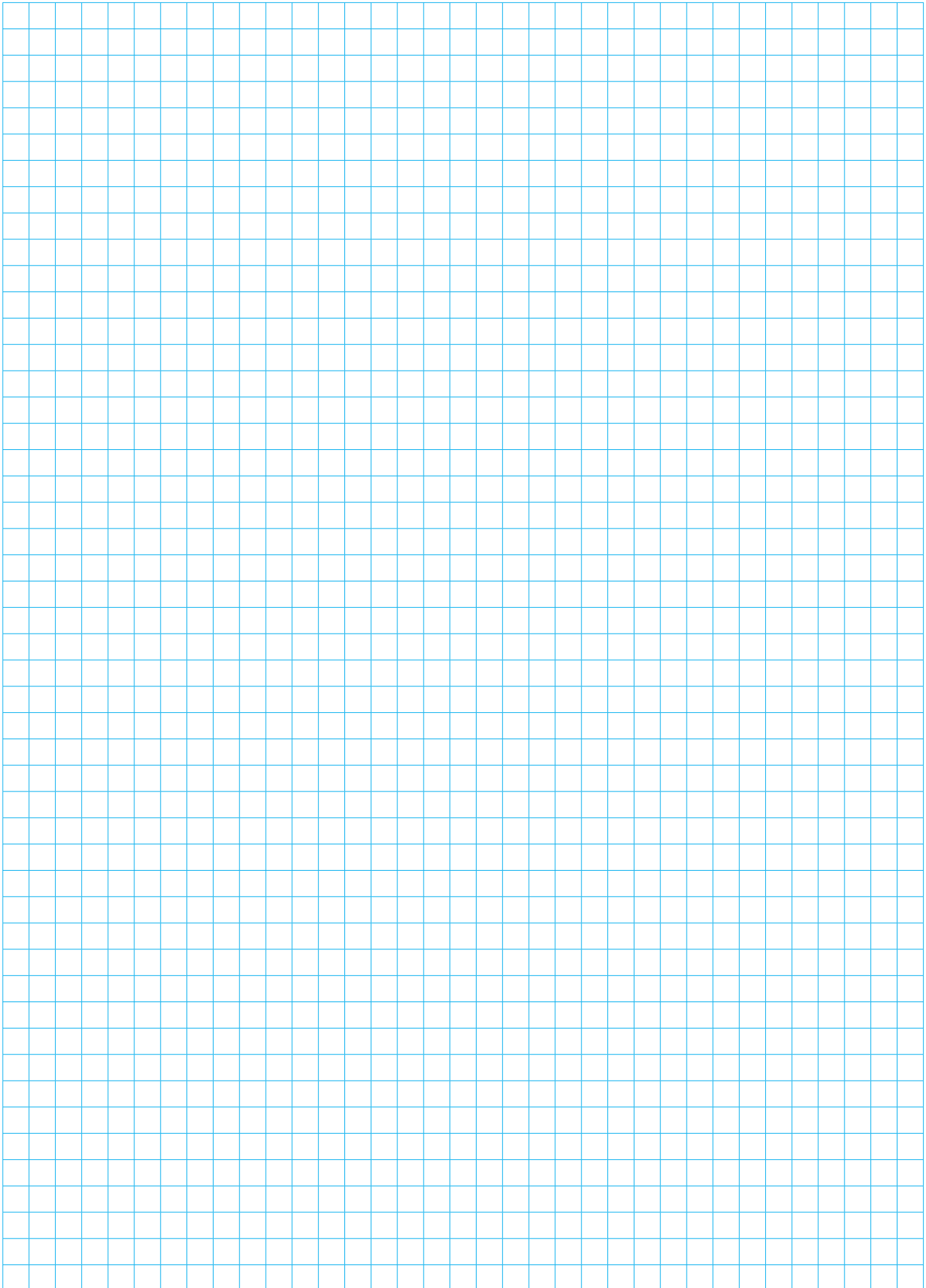

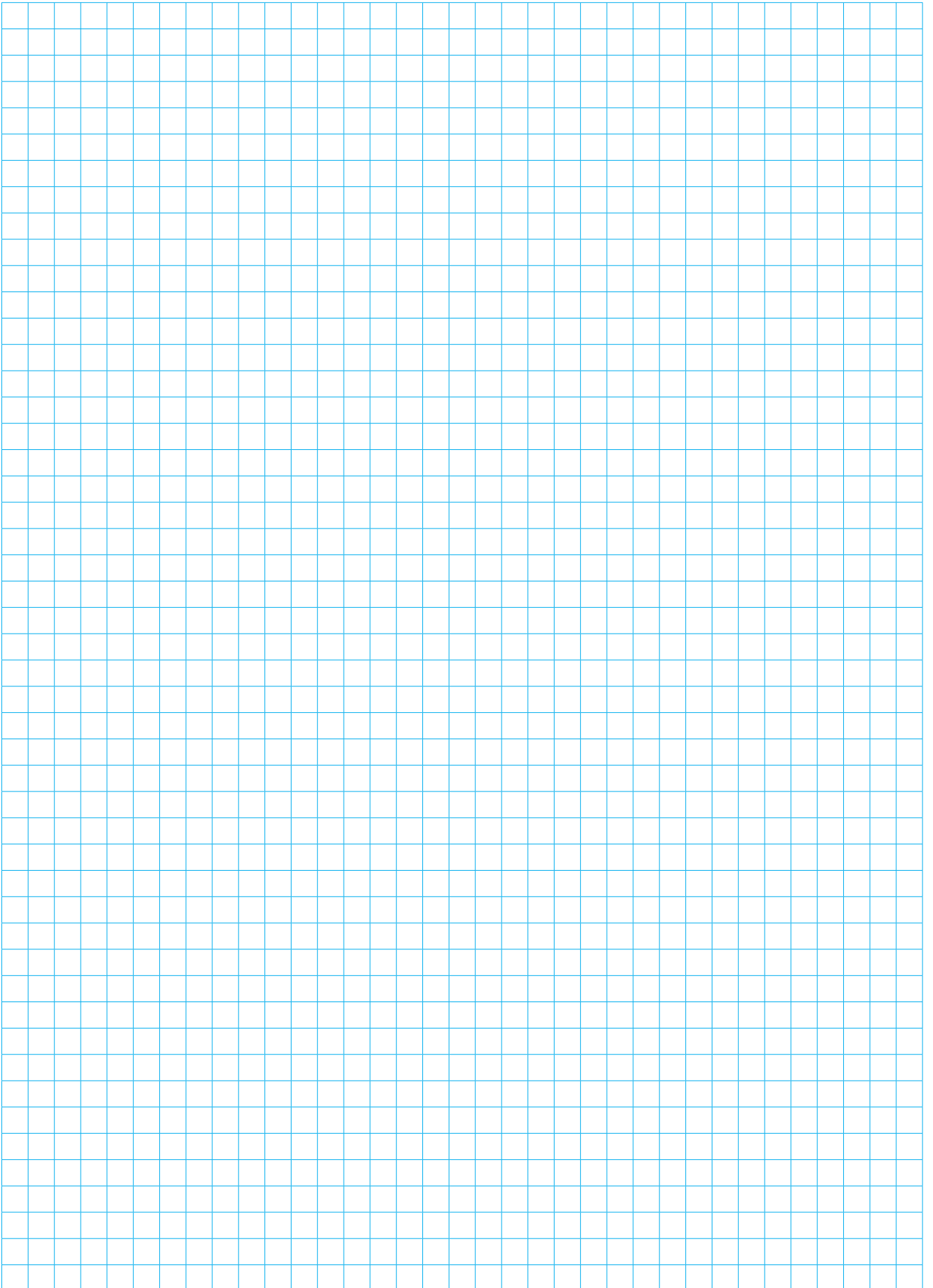



MORO KAISER **COMPONENTS**

MORO KAISER S.R.L.

Via Pontebbana, 16
33080 FIUME VENETO (PN) ITALY

Tel. 0434 951.211

Fax: 0434 957.786

infomoro@morokaiser.it